

General characteristics

Power supply		
Direct current voltage supply		✓
Nominal voltage range	Vdc	9 -> 75
Max. current	A	75

Motor characteristics (1)		12 Vdc	24 Vdc	32 Vdc	
At no load					
Max. output speed	rpm	1 700	3 230	4 500	
Current at the max output speed	A	1,1	1	2,4	
Standby current	mA	50	50	50	+/-10%
At nominal					
Speed	rpm	1 380	3 000	3 845	+/-10%
Torque (2)	N.m	1	1	1	
Output power	W	145	314	400	+/-10%
Current	A	15,4	15,4	15,4	
Efficiency	%	78	85	82	
At max. output power					
Speed	rpm	1 000	2 310	3 100	
Torque	N.m	2,5	2,5	2,5	
Output power	W	262	600	750	
Current	A	34,5	34,5	34,5	
Efficiency	%	60	74	68	
At peak torque					
Speed	rpm	1 000	2 310	3 100	
Torque	N.m	2,5	2,5	2,5	
Output power	W	262	605	750	
Current	A	34,5	34,5	34,5	

Others		
Life	h	20 000
Rotor inertia	gcm ²	426
Rotor poles		8
Cogging torque	mNm	45
Weight	kg	2,4
Noise level	dBA	55

Connecting		
I/O M16 connector 18 pins		
Optional logic supply	Pin N°	1
0 Volt		2
Input 6 (analogic 1)		3
Input 5 (analogic 2)		4
Input 1 (digital)		5
Input 2 (digital)		6
Input 3 (digital)		7
Input 4 (digital)		8
0 Volt		9
Output 1 (digital - PWM)		10
Output 2 (digital - PWM)		11
Output 3 (digital)		12
Output 4 (digital)		13
0 Volt		14
STO 2 -		15
STO 2 +		16
STO 1 -		17
STO 1 +		18
Power supply M16 connector 3 pins		
Output ballast	Pin N°	1
+VDC		2
0 Volt		3
CAN M12 Connector - 5 pins		
Not connected	Pin N°	1 / 2
CAN_GND		3
CAN_H		4
CAN_L		5

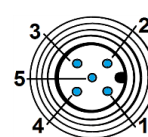
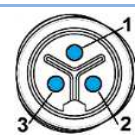
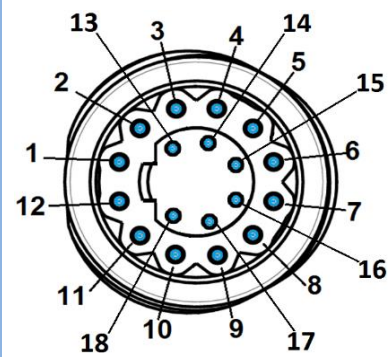

Drive		
Type	SMI22 CAN	
Built-in drive	✓	
Internal magnetic encoder	4096 pulses/rev	
Setting software on PC	DCmind soft+CANopen	
Control		
Position - speed - torque	✓	
4 quadrants	✓	
With regenerative energy absorber (3)	✓	
Type" Field Oriented Control"	✓	
Security		
Wrong polarity from power supply	✓	
Output shortcut	✓	
Input inverted	✓	
Low voltage	Vdc	<9
Overvoltage (4)	Vdc	> 75
Internal drive temperature protection	°C	110
Temperature drive allowing to restart	°C	90

Generic parameters			
Output shaft with ball bearings	✓		
2 Safe Torque Off inputs IEC61800-5-2/62061, ISO13849	✓		
Max. radial force (16mm from front face)	N	140	
Max. axial force	N	47	
Temperature range IEC60068-2-1/2	°C	-30 -> +70	
Storage temperature	°C	-40 -> +80	
Dielectric (1s/2mA) UL1004-1	Vdc	1 955	
Motor insulation IEC60085	class	E	
Salt spray ISO9227	severity	48h	
Degree of protection IEC60529 (output shaft not included)		IP67 + IP69	
EMC			
Electrostatic discharge IEC61000-4-2	level	3	
Radiated field IEC61000-4-3	level	3	
Electrical fast transient/burst test IEC61000-4-4	level	3	
Surge test IEC61000-4-5	level	1	
Conducted disturbances IEC61000-4-6	level	3	
Radiated emission EN55022	class	B	
Approvals			
ROHS 2011/65/CE	✓		
EC	✓		
UL	Pending		
CAN Open CIA DS 301/402	✓		
Communication			
USB (Setting, monitoring)	Micro-USB B		
CAN open: address - node ID (factory settings)		0x20	
CAN open: baud rate (factory settings)	kbaud	1000	

Notes	
Values without tolerances are average production values.	
(1) Cold motor, 20°C ambient temp., full speed, sinusoidal commutation	
(2) Nominal torque for continuous operation at 20 °C, decrease this value for higher ambient temperature	
(3) Ballast resistor to be added	
(4) Can be configured via DCmind soft+CANopen	
* V1: see label on product	

Additional information is available in the SQ75 product user manual and in the starter kit manual, available in www.crouzet.com

Drive electrical data

Running data				
Parameters		Min.	Typical	Max.
Voltage power supply "Vdc"	Vdc	9	24	75
Current "Idc"	A	-	15	60
Standby power "Wo"	W	-	2	-
Voltage optional logic supply (see wiring diagram)	Vdc	9	-	75*

* UL: maximum voltage supply: 36 Vdc

CAN Bus characteristics				
Parameters		Min.	Typical	Max.
CAN_L insulated	Vdc	0,5	1,5	2,25
CAN_H insulated	Vdc	2,75	3,5	4,5

Accessories

Starter kit				
Part number	79 513 105			
Power/logic/CAN 3 m cables - Software - USB to Can Open adapter - CAN terminal resistor - CAN double connector				
Power supply cable	79 298 664	3m length	AWG18	
Input-Output cable	79 513 106	3m length	AWG24	
CAN cable M12	27 358 015	1m length	AWG26	

Input data					
Parameters		Min.	Typical	Max.	
Input 1, 2, 3, 4	Impedance	kΩ	-	247	-
	Low level	Vdc	-90	-	2,4
	High level	Vdc	4,5	-	90
Input 5, 6	Impedance	kΩ	-	159	-
	Low level	Vdc	-90	-	2
	High level	Vdc	7,1	-	90
Inputs STO	Low level	Vdc	-2	-	4
	High level	Vdc	4,6	-	75

Output data				
Parameters		Min.	Typical	Max.
Low level Output 1, 2, 3, 4	mVdc	-	-	10
High level Output 1, 2, 3, 4	Vdc	-	4,75	-
Max output current "I outmax"	mA	-	-	50
I sink	mA			600

Speed-torque and current-torque curves

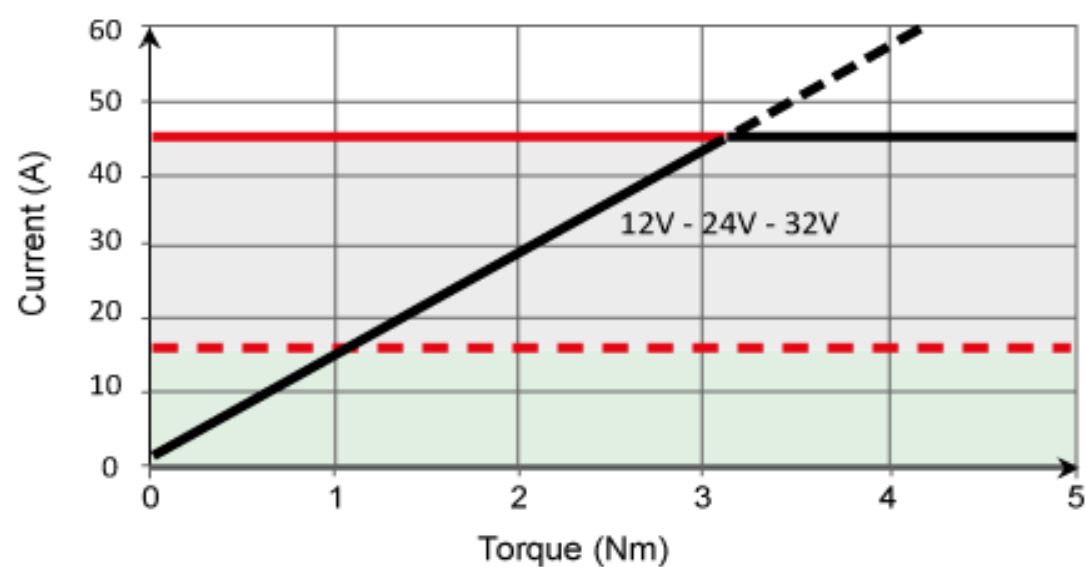
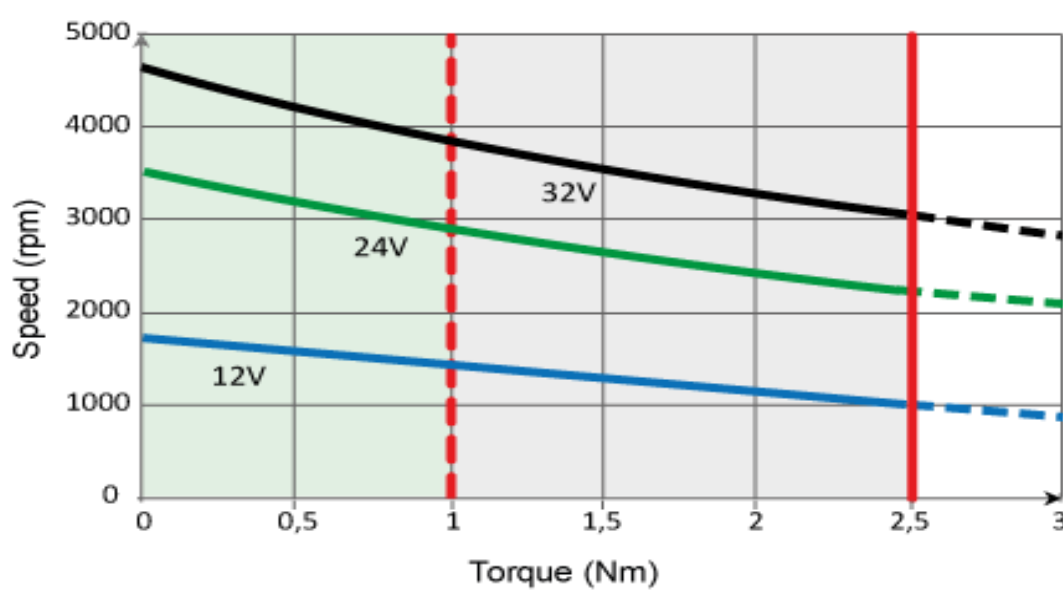

- - - Nominal — Peak Continuous running Cycling

Wiring

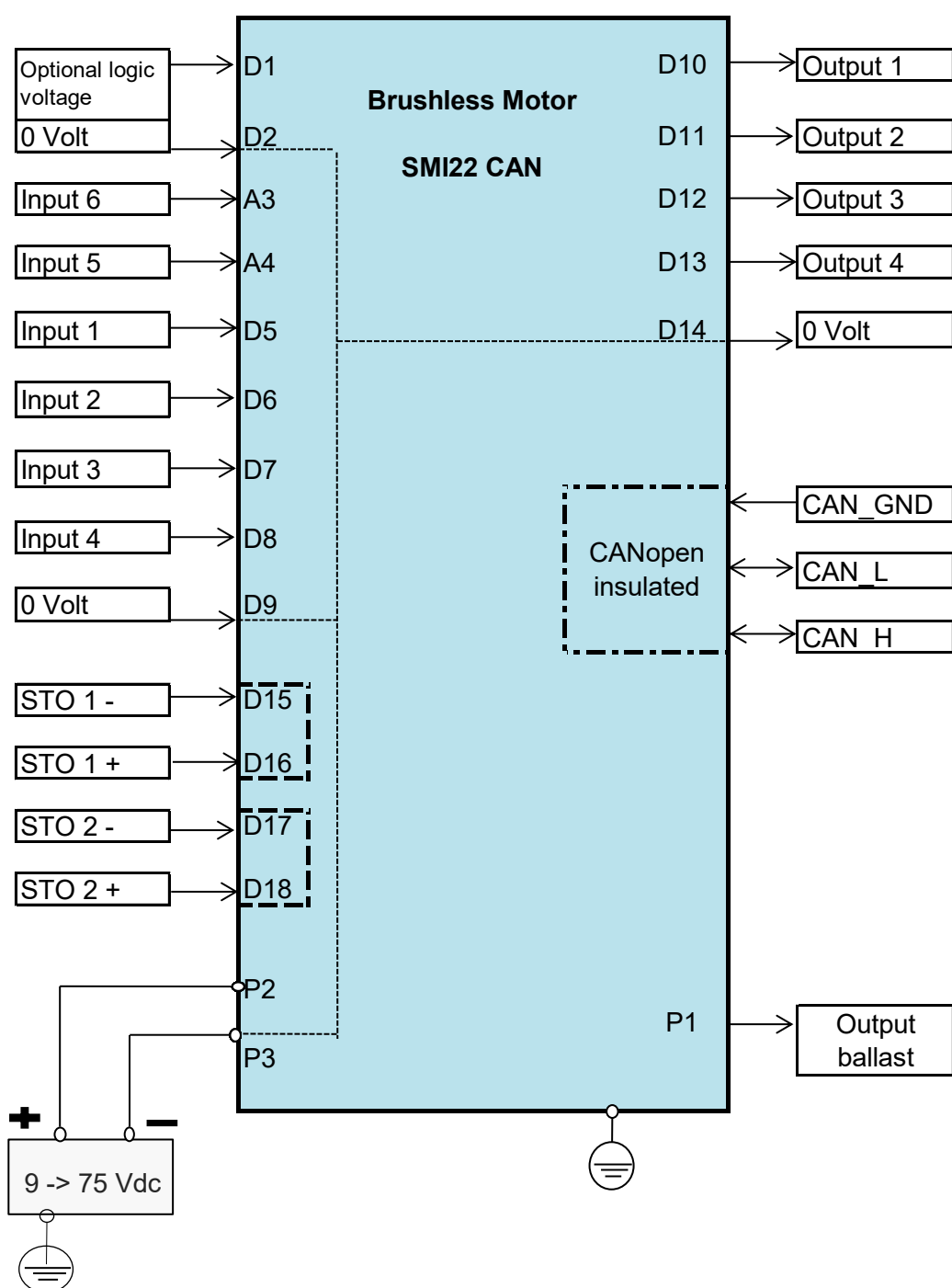

Input equivalent circuit

Inputs 1, 2, 3, 4

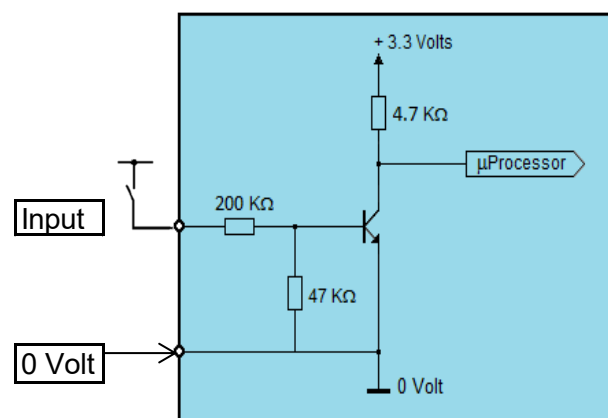

Inputs 5, 6

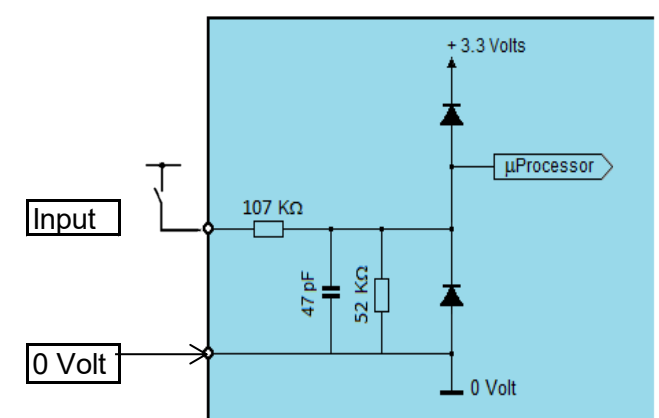

Output equivalent circuit

Output 1,2,3,4

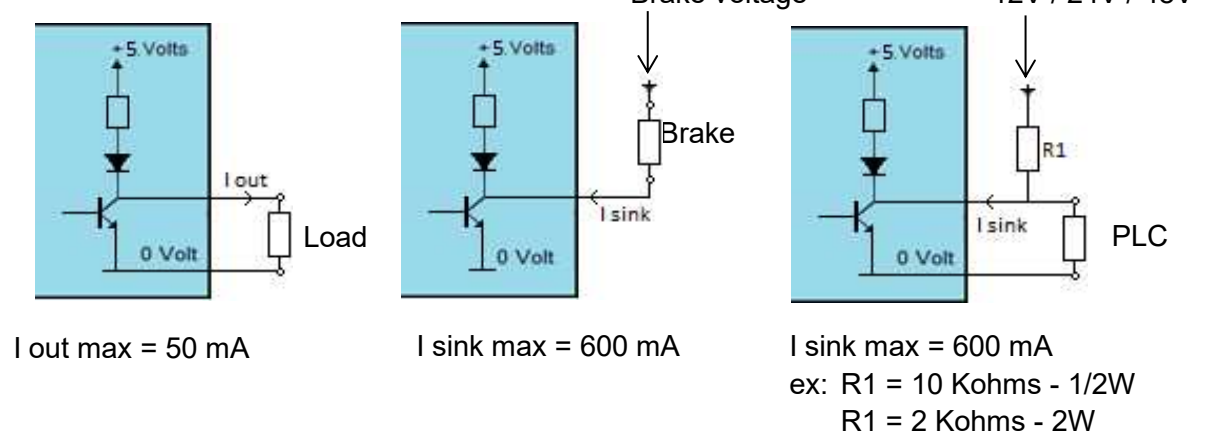

Output ballast

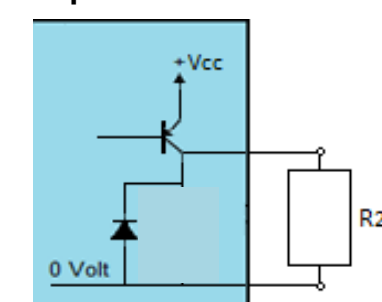

Regenerative energy created per inertia load creates over-voltage. In case of too high value, connect R2 resistor through ballast output and ground to absorb this energy. Typical R2 value is 2.2 Ω. Power value depends from machine inertia. Max. voltage can be set.

Specifications subject to change without notice. Updated 03.10.2019

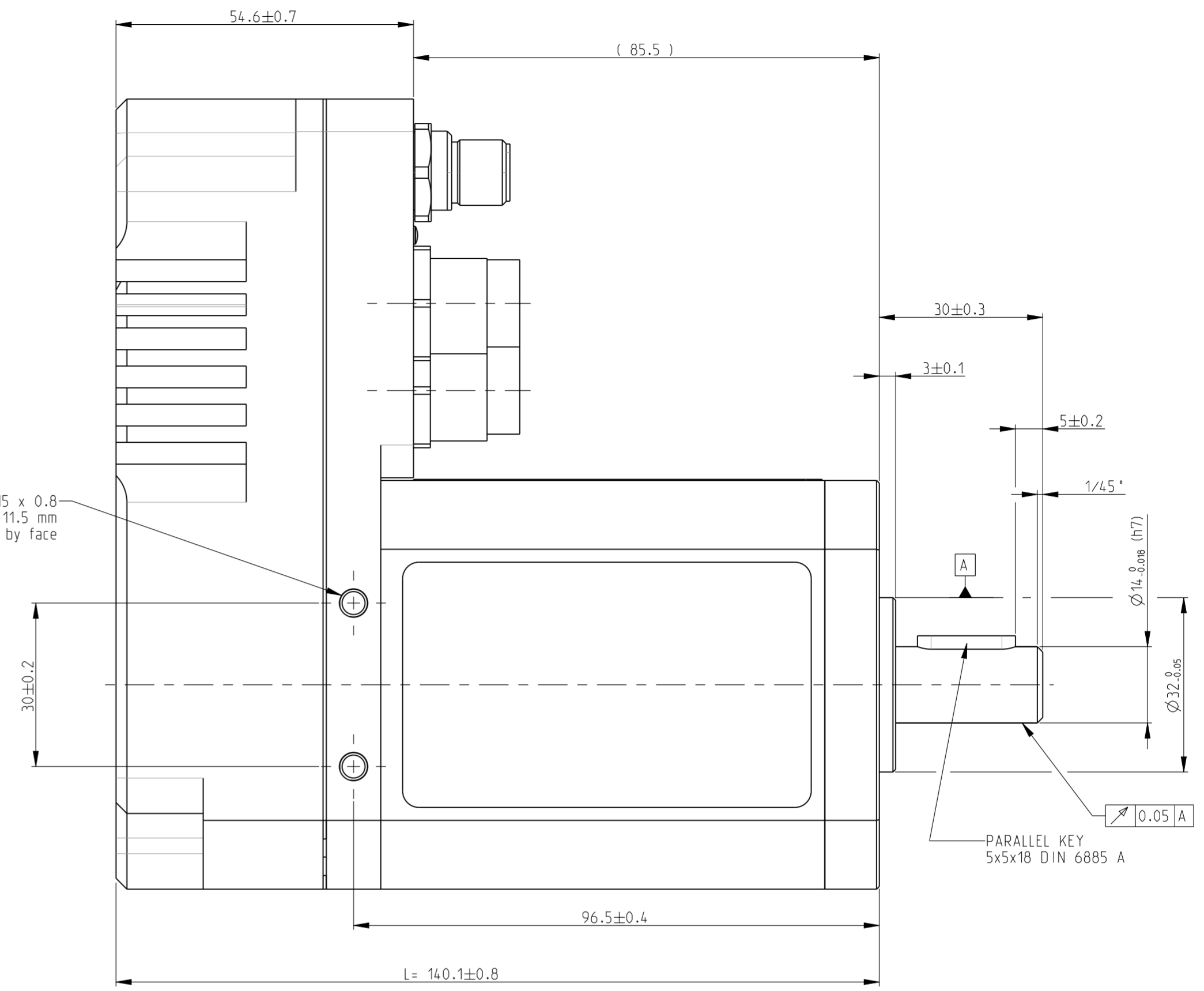
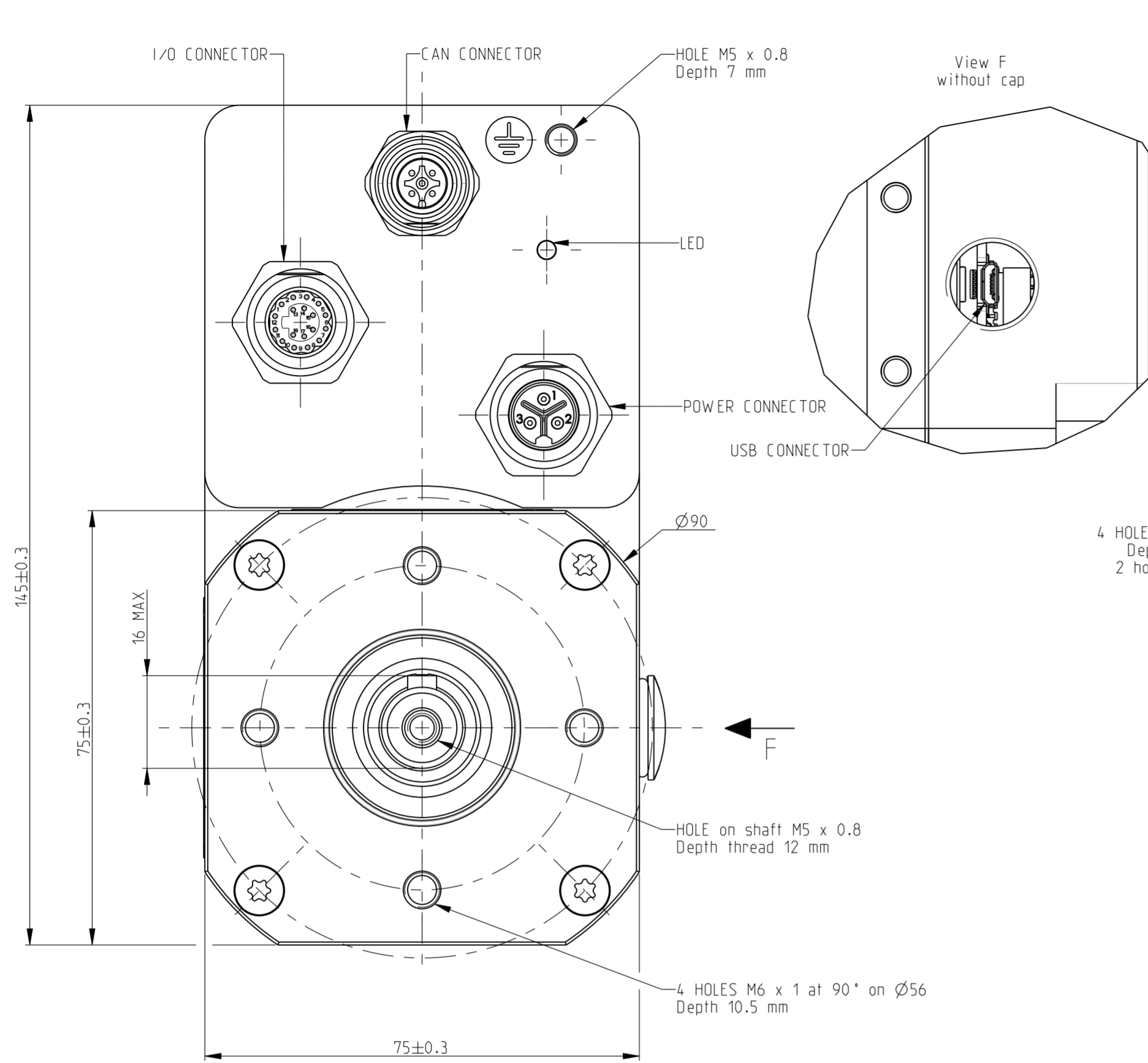

SQ75-1 80350 L: 140.9 MAX

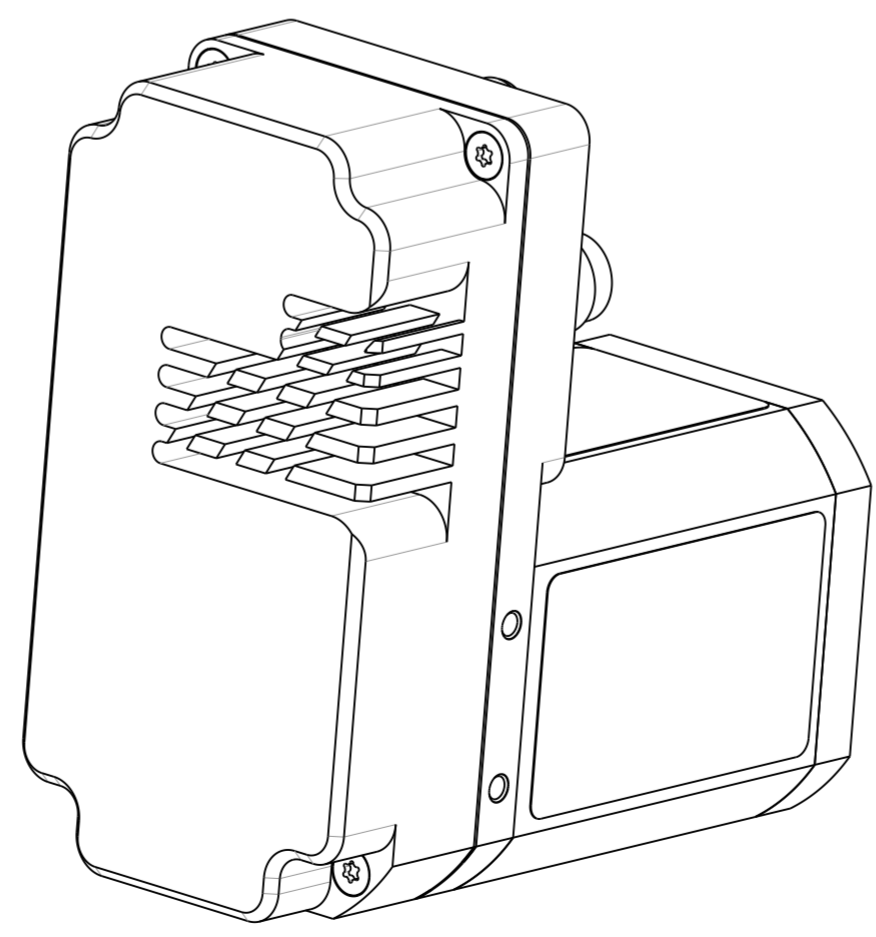
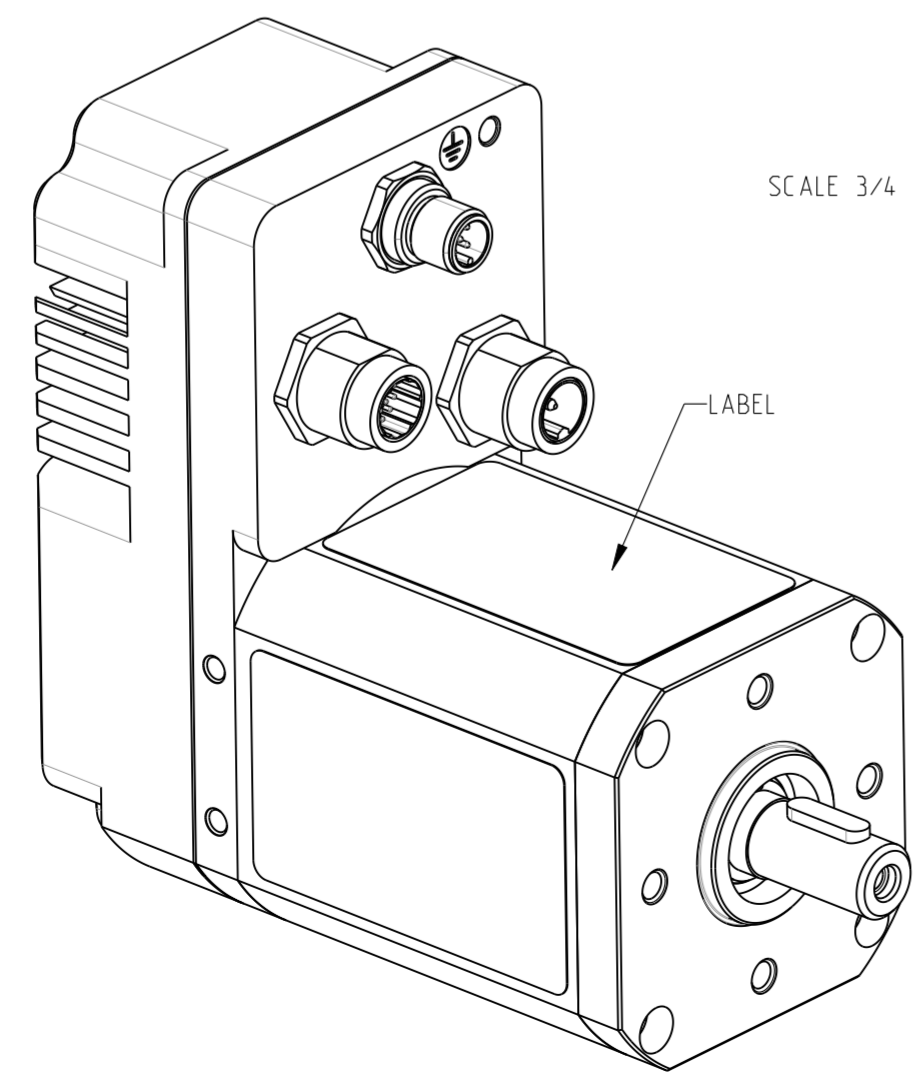

80350001 - V1
CROUZET