



General characteristics

Part numbers						
Geared motor		8036D001	8036D002	8036D003	8036D004	8036D005
Geared motor + brake		8036D101	8036D102	8036D103	8036D104	8036D105
Gearbox characteristics						
Gearbox type		Planetary PM72				
Number of stages		1 stage	2 stages	3 stages		
Max. radial force (16mm from front f	N	320	480	760		
Max. axial force	N	70	100	160		
RATIO						
		6,75	25,01	45,56	92,7	168,84
Max. allowed torque	Nm	14	42	42	84	84
Max. gear play	°	0,6	0,7	0,7	0,7	0,7
Geared motor characteristics at 32V (5)						
At no load						
Max. output speed	rpm	484	131	72	35	19
Standby current	mA	50	50	50	50	50
At nominal						
Speed	rpm	439	118	65	32	18
Torque (2)	Nm	7,0	24,4	42,0	84,0	84,0
Output power	W	322	302	287	283	162
Current	A	14	14	14	14	14
Efficiency	%	70	66	62	61	35
At max. output power						
Speed	rpm	393	109	65	32	18
Torque	Nm	14	42	42	84	84
Output power	W	576	481	287	283	162
Current	A	42	42	42	42	42
Efficiency	%	43	36	21	21	12
At peak torque						
Speed	rpm	393	109	65	32	18
Torque	Nm	14	42	42	84	84
Output power	W	576	481	287	283	162
Current	A	42	42	42	42	42
Others						
Weight without brake	kg	4,1	4,6	4,6	5,1	5,1
Weight with brake	kg	4,8	5,3	5,3	5,8	5,8

Connecting

I/O M16 connector 18 pins	Pin N°	
Optional logic supply	1	
0 Volt	2	
Input 6 (analogic 1)	3	
Input 5 (analogic 2)	4	
Input 1 (digital)	5	
Input 2 (digital)	6	
Input 3 (digital)	7	
Input 4 (digital)	8	
0 Volt	9	
Output 1 (digital - PWM)	10	
Output 2 (digital - PWM)	11	
Output 3 (digital)	12	
Output 4 (digital)	13	
0 Volt	14	
STO 2 -	15	
STO 2 +	16	
STO 1 -	17	
STO 1 +	18	
Power supply M16 connector 3 pins	Pin N°	
Output ballast	1	
+VDC	2	
0 Volt	3	
CAN M12 Connector - 5 pins	Pin N°	
Not connected	1 / 2	
CAN_GND	3	
CAN_H	4	
CAN_L	5	
Brake connector	Pin N°	
0 Volt	1	
24 Vdc	3	
Not connected	4	

Motor Characteristics (1)

Motor type	80 360 001 V1*	
Direct current voltage supply	✓	
Nominal voltage range	Vdc	9 --> 75
Max.current	A	75

Drive

Type	SMI22 CAN	
Built-in drive	✓	
Internal magnetic encoder	4096 pulses/rev	
Setting software on PC	DCmind soft CAN Open	
Control		
Position - speed - torque	✓	
4 quadrants	✓	
With regenerative energy absorber (3)	✓	
Type" Field Oriented Control"	✓	
Security		
Wrong polarity from power supply	✓	
Output shortcut	✓	
Input inverted	✓	
Low voltage	Vdc	< 9
Overvoltage (4)	Vdc	> 75
Internal drive temperature protection	°C	110
Temperature drive allowing to restart	°C	90

Geared motor parameters

Output shaft with ball bearings	✓	
2 Safe Torque Off inputs	IEC61800-5-2/62061, ISO13849	✓
Temperature range	IEC60068-2-1/2	°C -30 -> +70
Storage temperature		°C -40 -> +80
Dielectric (1s/2mA)	IEC60335	Vdc 1 955
Motor insulation	IEC60085	class E
Salt spray	ISO9227	severity 48h
EMC		
Electrostatic discharge	IEC61000-4-2	level 3
Radiated field	IEC61000-4-3	level 3
Electrical fast transient/burst test	IEC61000-4-4	level 3
Surge test	IEC61000-4-5	level 1
Conducted disturbances	IEC61000-4-6	level 3
Radiated emission	EN55022	class B

Approvals

ROHS	2011/65/CE	✓
EC		✓
UL		Pending
CAN Open	CIA 301 - DSP 402	✓

Communication

USB (Setting, monitoring)	Micro-USB B	
CAN open: address - node ID (factory settings)		0x20
CAN open: baud rate (factory settings)	kbaud	1 000

Brake characteristics

Power OFF brake	YES	
Voltage supply	Vdc	24 (+6% ; -10%)
Nominal holding torque	Nm	4,5
Input power	W	12

Notes

- Values without tolerances are average production values.
- (1) Cold motor, 20°C ambient temp., full speed, sinusoidal commutation
- (2) Nominal torque for continuous operation at 20 °C, decrease this value for higher ambient temperature
- (3) Ballast resistor to be added
- (4) Can be configured via DCmind soft+CANopen
- (5): Other values available, please refer to direct motor datasheet
- * V1: see label on product

Additional information is available in the SQ75 product user manual and in the starter kit manual, available in www.crouzet.com

Drive electrical data

Running data

Parameters		Min.	Typical	Max.
Voltage power supply "Vdc"	Vdc	9	24	75
Current "Idc"	A	-	15	60
Standby power "Wo"	W	-	2	-
Voltage optional logic supply (see wiring diagram)	Vdc	9	-	75*

* UL: maximum voltage supply: 36 Vdc

CAN Bus characteristics

Parameters		Min.	Typical	Max.
CAN_L insulated	Vdc	0,5	1,5	2,25
CAN_H insulated	Vdc	2,75	3,5	4,5

Accessories

Starter kit

Part number **79 513 105**

Power/logic/CAN 3 m cables - Software - USB to Can Open adapter - CAN terminal resistor - CAN double connector

Power supply cable	79 298 664	3m length	AWG18
Input-Output cable	79 513 106	3m length	AWG24
CAN cable M12	27 358 015	1m length	AWG26

Wiring

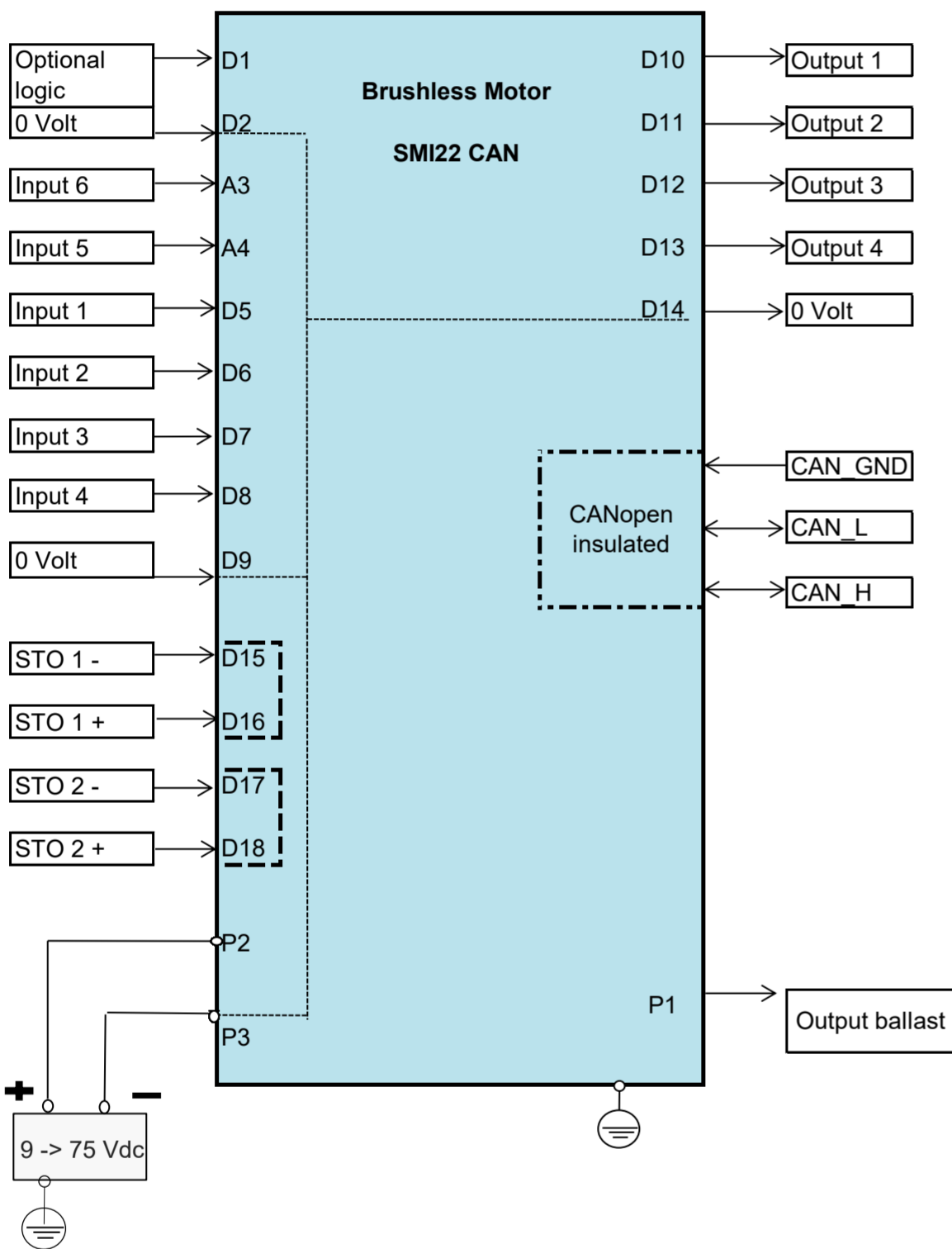

Input data

Parameters		Min.	Typical	Max.
Input 1, 2, 3, 4	Impedance	kΩ	-	247
	Low level	Vdc	-90	-
	High level	Vdc	4,5	-
Input 5, 6	Impedance	kΩ	-	159
	Low level	Vdc	-90	-
	High level	Vdc	7,1	-
Inputs STO	Low level	Vdc	-2	-
	High level	Vdc	4,6	-

Output data

Parameters		Min.	Typical	Max.
Low level Output 1, 2, 3, 4	mVdc	-	-	10
High level Output 1, 2, 3, 4	Vdc	-	4,75	-
Max output current "I outmax"	mA	-	-	50
I sink	mA	-	-	600

Input equivalent circuit

Inputs 1, 2, 3, 4

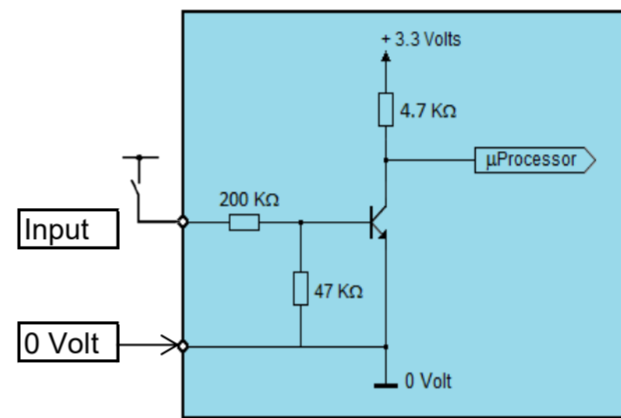

Inputs 5, 6

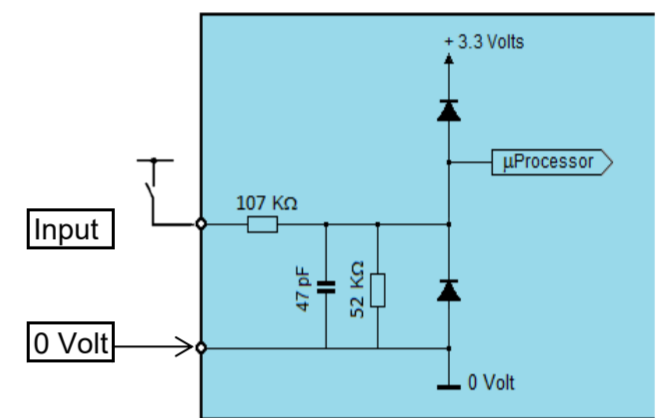

Output equivalent circuit

Output 1,2,3,4

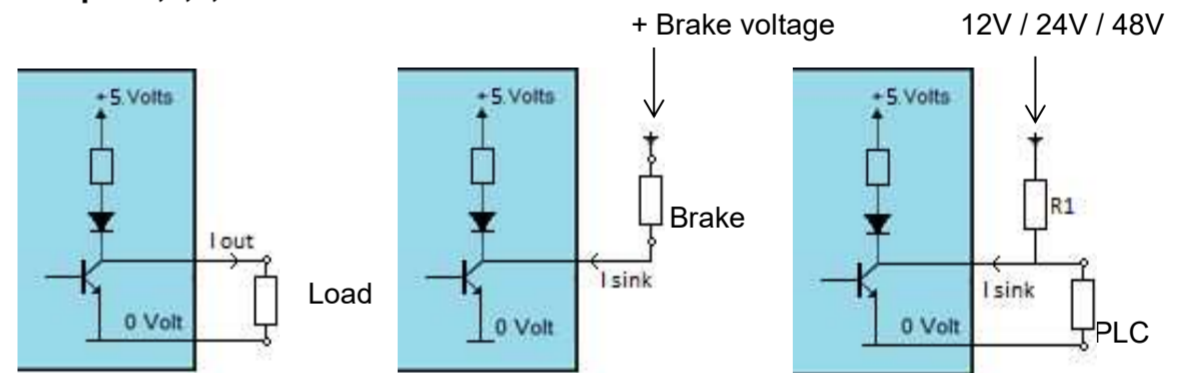

I out max = 50 mA

I sink max = 600 mA

I sink max = 600 mA
ex: R1 = 10 Kohms - 1/2W
R1 = 2 Kohms - 2W

Output ballast

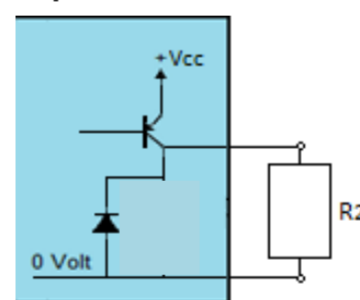

Regenerative energy created per inertia load creates over-voltage. In case of too high value, connect R2 resistor through ballast output and ground to absorb this energy. Typical R2 value is 2.2 Ω. Power value depends from machine inertia. Max. voltage can be set.

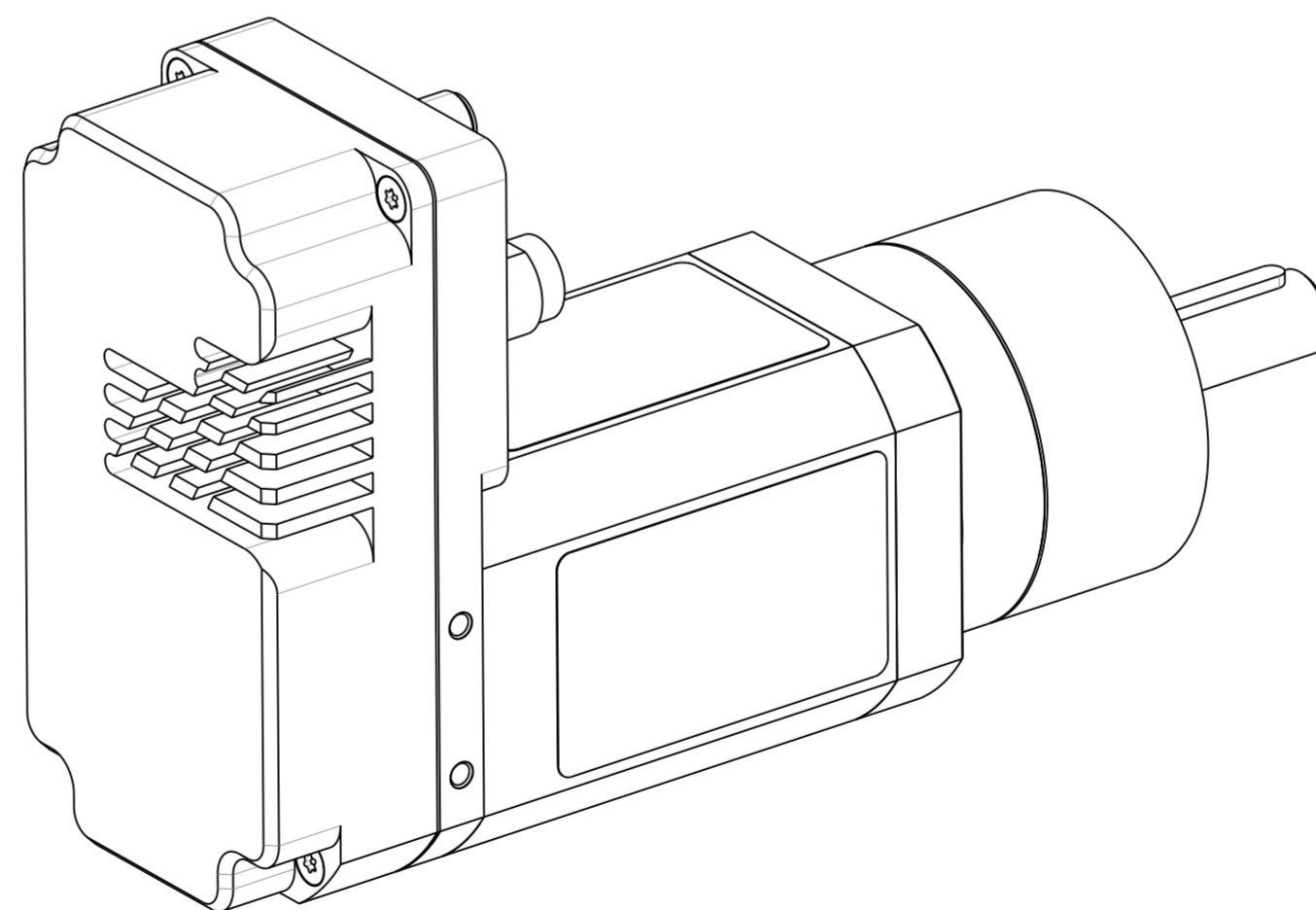
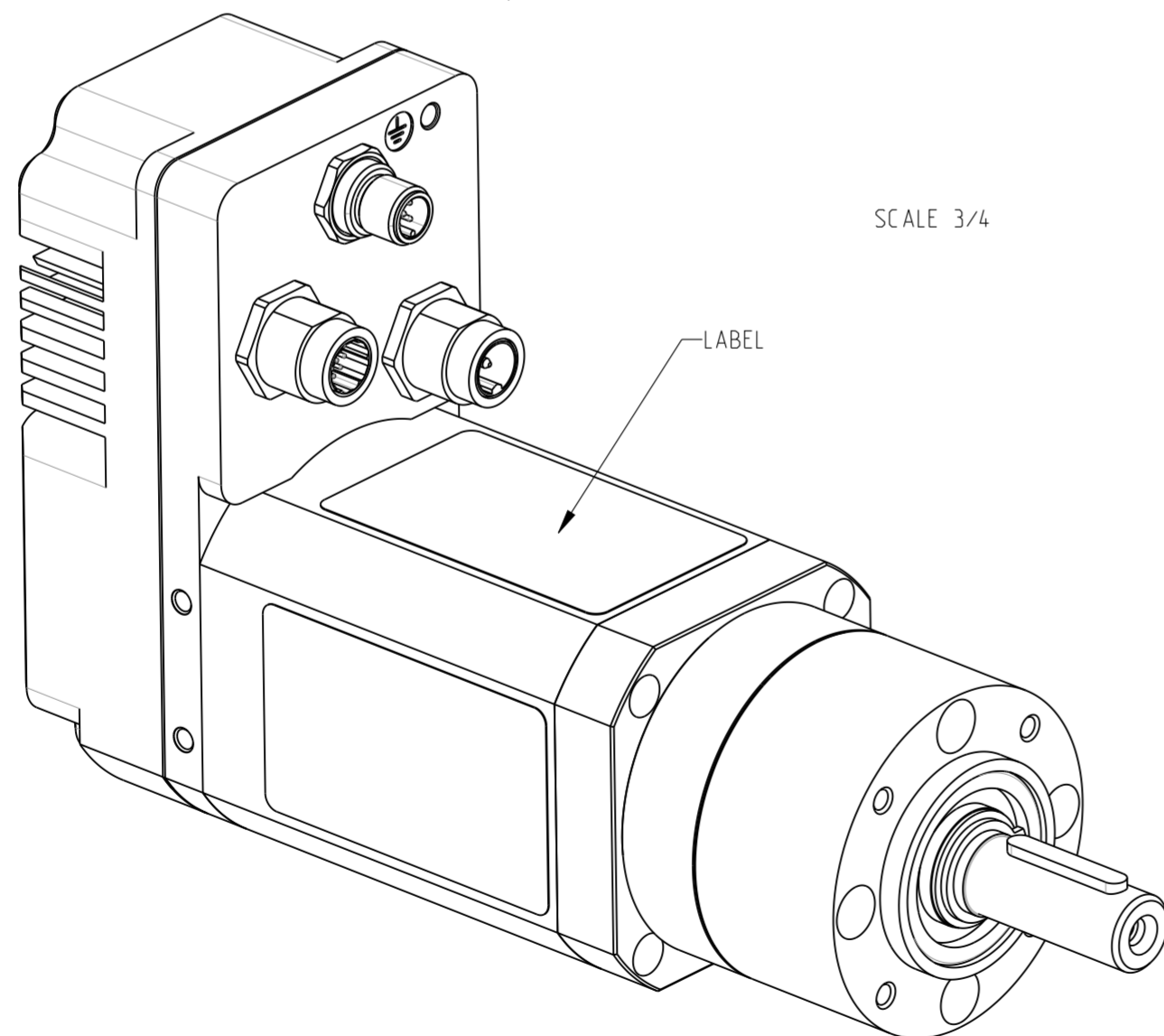
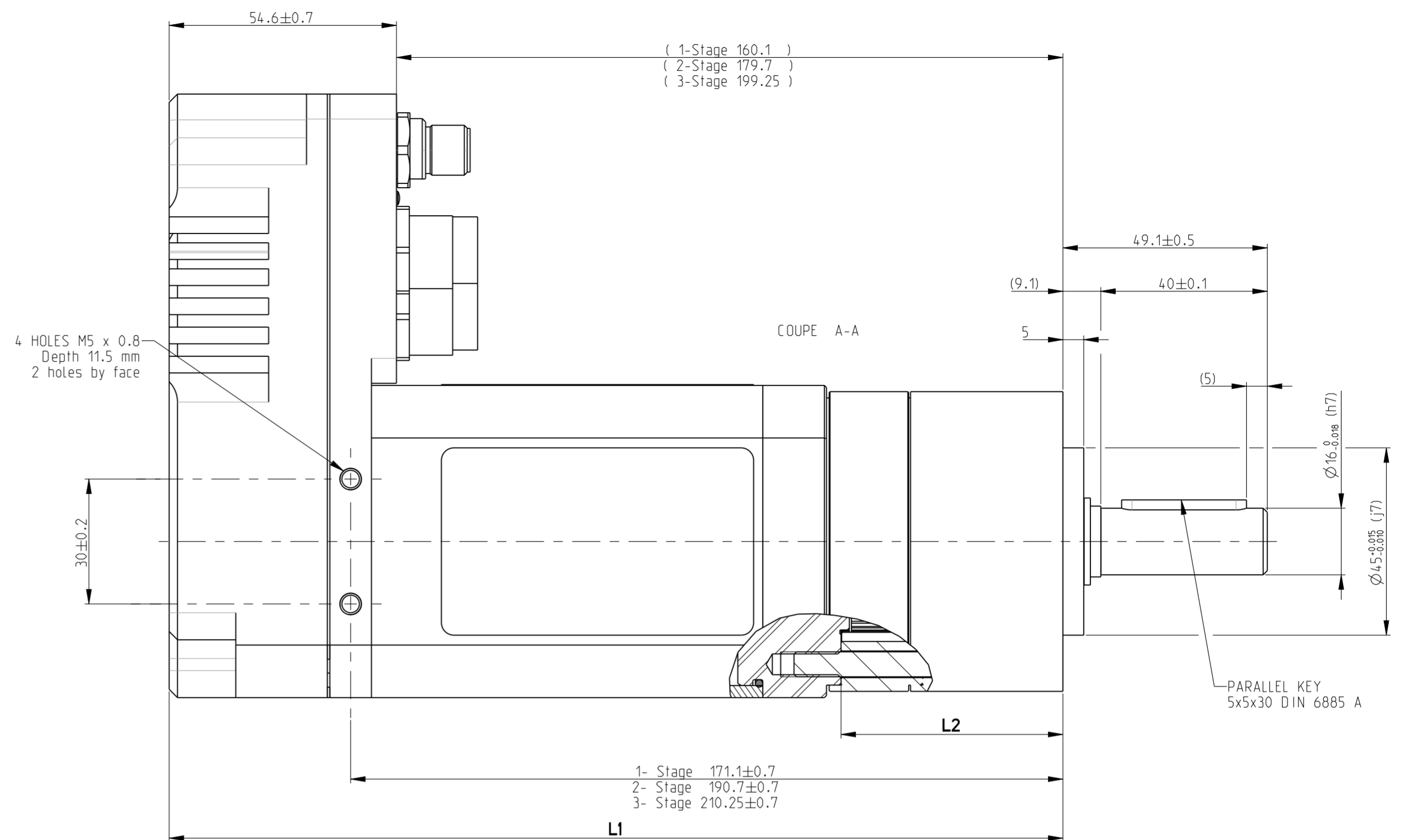
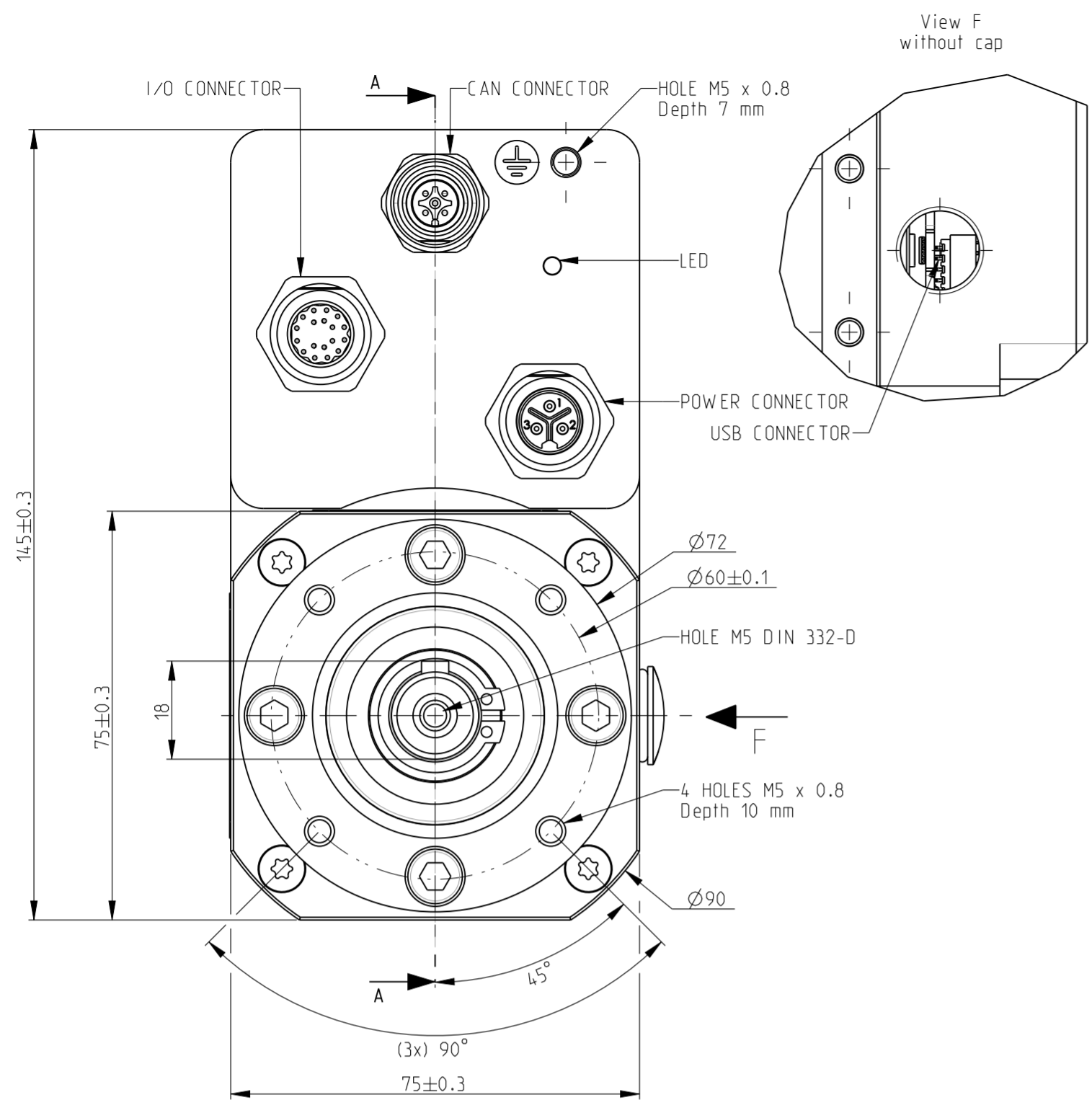

	L1 (±1)	L1 MAX
PM72 1-STAGE	214.70	215.80
PM72 2-STAGE	234.30	235.40
PM72 3-STAGE	253.85	254.95

	L2 (±0.3)	L2 MAX
PM72 1-STAGE	53.30	53.60
PM72 2-STAGE	72.90	73.20
PM72 3-STAGE	92.45	92.75

	GEAR MOTOR AVAILABLE					
	80 36D 001	80 36D 002	80 36D 003	80 36D 004	80 36D 005	80 36D 006
	REDUCTION GEARBOX AVAILABLE					
RAPPORT	7:1	25:1	46:1	93:1	169:1	308:1
NB_STAGE	1	2	2	3	3	3
REFERENCE_FOURNISSEUR	PM72/PM 7:1	PM72/PM 25:1	PM72/PM 46:1	PM72/PM 93:1	PM72/PM 169:1	PM72/PM 308:1
POIDS	1.4 Kg	1.9 Kg	1.9 Kg	2.4 Kg	2.4 Kg	2.4 Kg
JEU_ANGULAIRE_MAXI	0.6°	0.65°	0.65°	0.7°	0.7°	0.7°
DIAM_ARBRE_MOTEUR	16	16	16	16	16	16
Reference	79297960	79297961	79297962	79297963	79297964	79297965

80360 V1 + PM72



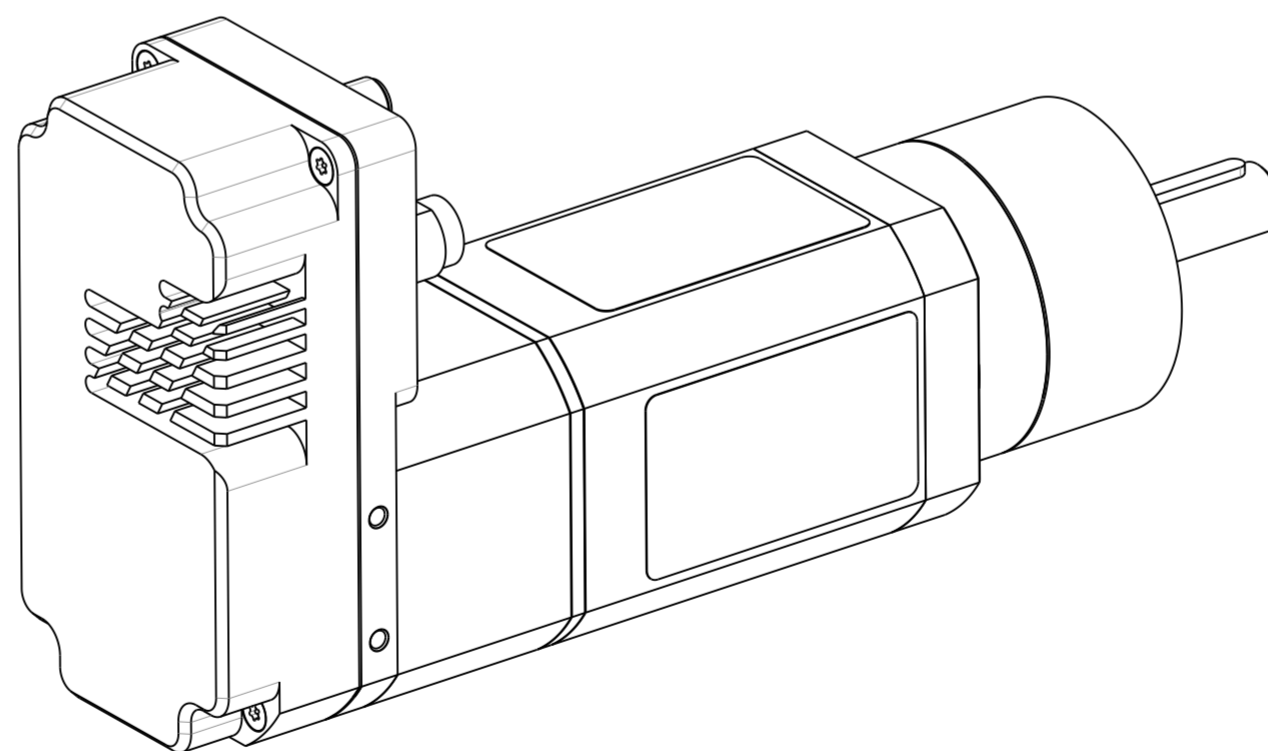
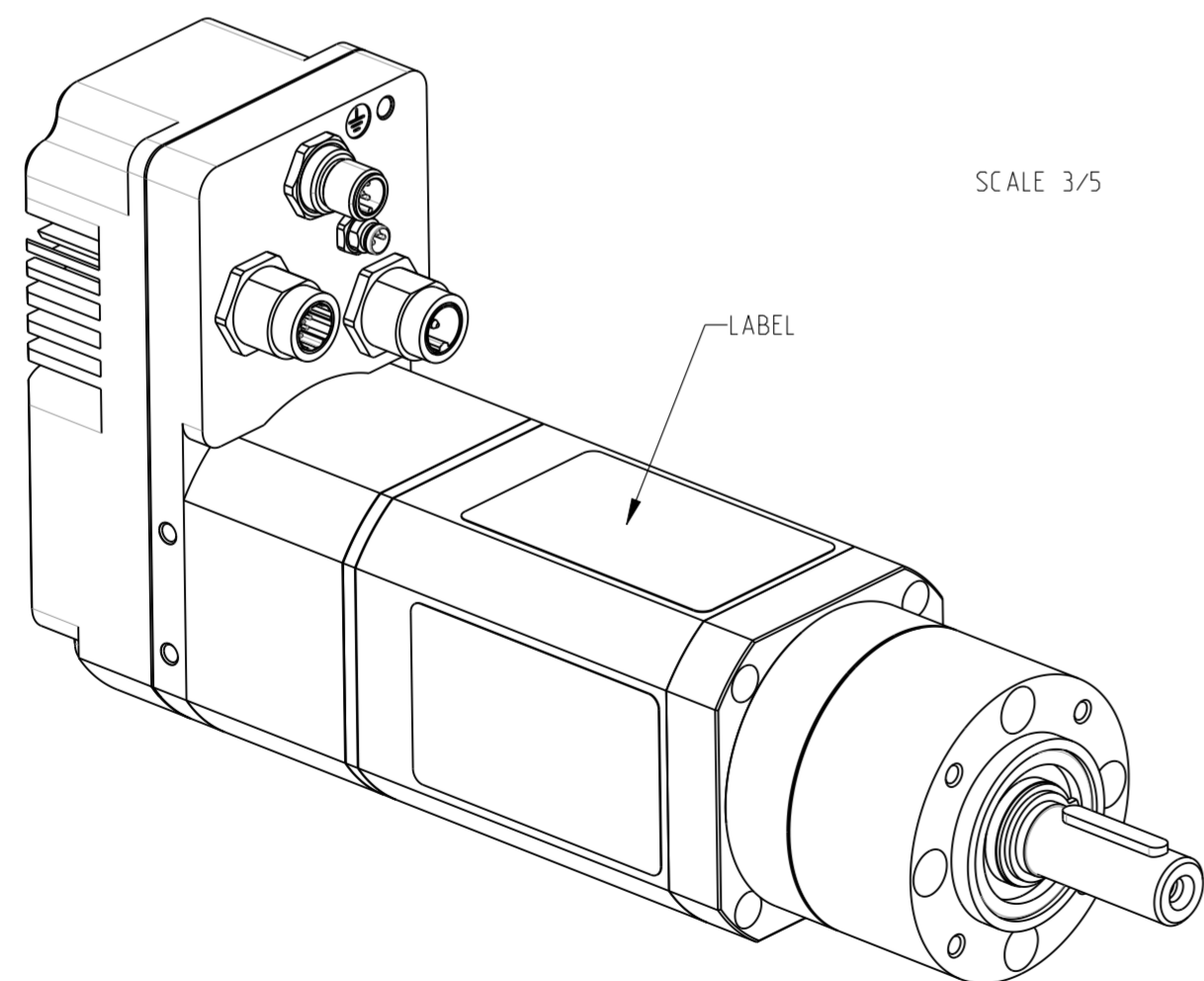
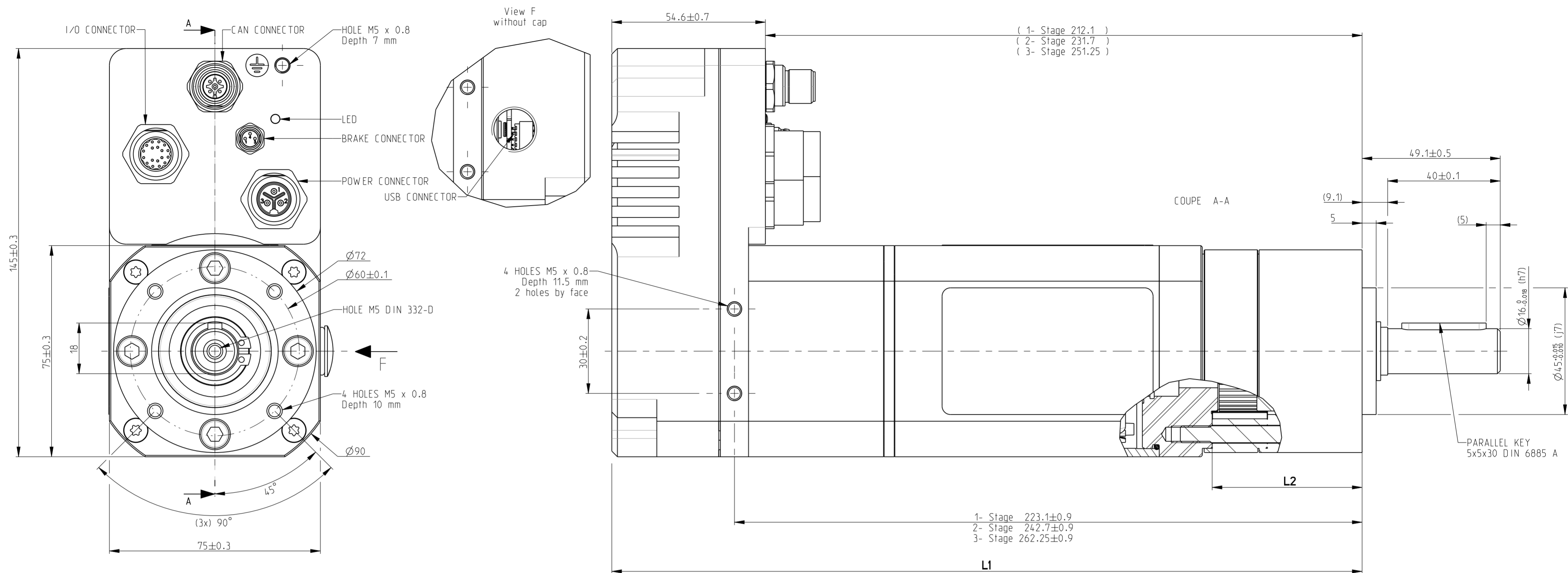

	L1 (±13)	L1 MAX
PM72 1-STAGE	266.70	268.00
PM72 2-STAGE	286.30	287.60
PM72 3-STAGE	305.85	307.15

	L2 (±0.3)	L2 MAX
PM72 1-STAGE	53.30	53.60
PM72 2-STAGE	72.90	73.20
PM72 3-STAGE	92.45	92.75

	GEAR MOTOR AVAILABLE					
	80 36D 101	80 36D 102	80 36D 103	80 36D 104	80 36D 105	80 36D 106
	REDUCTION GEARBOX AVAILABLE					
RAPPORT	7:1	25:1	46:1	93:1	169:1	308:1
NB_STAGE	1	2	2	3	3	3
REFERENCE_FOURNISSEUR	PM72/PM 7:1	PM72/PM 25:1	PM72/PM 46:1	PM72/PM 93:1	PM72/PM 169:1	PM72/PM 308:1
POIDS	1.4 Kg	1.9 Kg	1.9 Kg	2.4 Kg	2.4 Kg	2.4 Kg
JEU_ANGULAIRE_MAXI	0.6°	0.65°	0.65°	0.7°	0.7°	0.7°
DIAM_ARBRE_MOTEUR	16	16	16	16	16	16
Reference	79297960	79297961	79297962	79297963	79297964	79297965

80360 V1 + PM72 + BRAKE

