



Medical



Laboratory



Industry



dcmind
BRUSH MOTORS

The power of silence

About US

Crouzet, a brand of CST (Custom Sensors & Technologies), is specialized in the core technologies required to design and manufacture high performance DC Geared Motors for use in the most demanding applications.

With a long term commitment to technological excellence, the engineering teams have mastered the following core technologies and know-how:

- Electromagnetism
- Electromechanical systems
- Thermal dynamics
- Electronic drives

Crouzet's extensive range of DC Brush and Brushless Motors have been designed to perform in the most demanding conditions for applications where safety and reliability are key issues.

Covering the power range 1 to 400 watts, associated with spur, worm and planetary gearboxes plus adapted controllers, our offer is specifically designed for Medical Equipment, Railways, Aeronautics, Industry Pumps and Valves.

Special products

Engineers and teams Dedicated project

From the very start of a project, Crouzet experts work closely with your teams to develop the specification. All our design, industrialization and approval expertise goes into developing Motion Control solutions that are tailored to your requirements.

Adapted products

Customer Adaptation Center

Defined in coordination between your project teams and our specialists, these adapted products have exactly the right levels of performance and functionality you need for your applications.

Standard products

Sales service

A full range of motors, geared motors and associated controllers, you can create your automation control applications as quickly as possible.

Products with added value

Customer Adaptation Center

All our standard products can have additional factory-mounted auxiliaries or accessories: connectors, leads, special terminals, dedicated shafts, adaptor plates, etc.

Seamless integration in your equipment means you benefit from simpler logistics and optimum installation reliability.

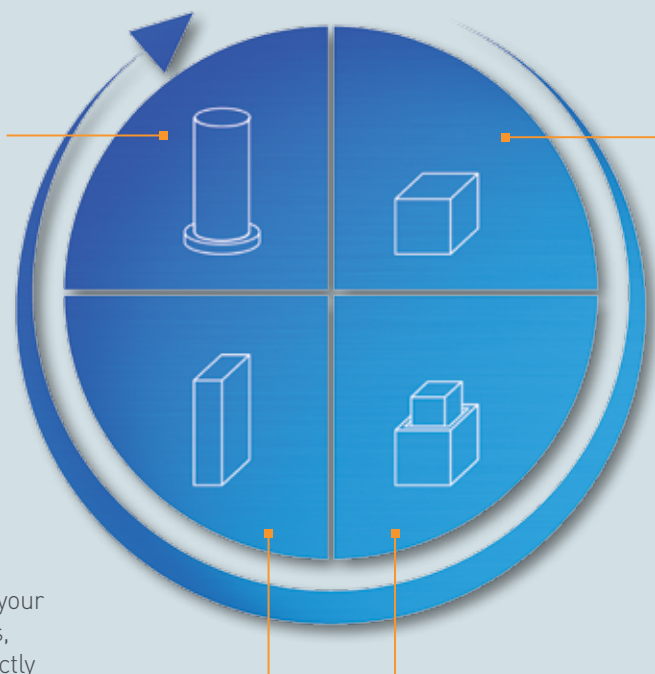



Custom Sensors & Technologies (CST) is a specialist in sensing, control and motion products.

Through its brands, BEI Kimco, BEI Sensors, BEI PSSC, Crouzet, Crydom, Kavlico, Newall and Systron Donner Inertial, CST offers customizable, reliable and efficient components for mission-critical systems in Aerospace & Defence, Transportation, Energy & Infrastructures, Commercial & Industrial OEMs, Medical, Food and Beverage and Building Equipment markets.

Focused on premium value offers and committed to excellence, CST, with 4,700 employees worldwide and sales of \$660M US in 2011, is the dependable and adaptable partner for the most demanding customers.

www.cstsensors.com

The Motors team worldwide

- Production sites
- Sales subsidiaries



DCmind Brush

The new generation

With more than 50 years' experience, Crouzet, a specialist in customized Motion Solutions, now launches its new DCmind Brush range of direct current Brush motors.

Designed by the engineers in Crouzet's Motors division, this new range - the quietest on the market - is ideally suited to the medical, industrial and printing sectors.

PRODUCT BENEFITS:

- Exceptionally quiet: 35 dBA
- Service life up to 24,000 hours
- More than 80% efficiency
- Output power up to 104 W
- 12, 24, 48, 90 and 120 V_{DC} power supplies and other voltages on request
- Up to IP69K
- Conformity to the specific standards for your market and required approvals

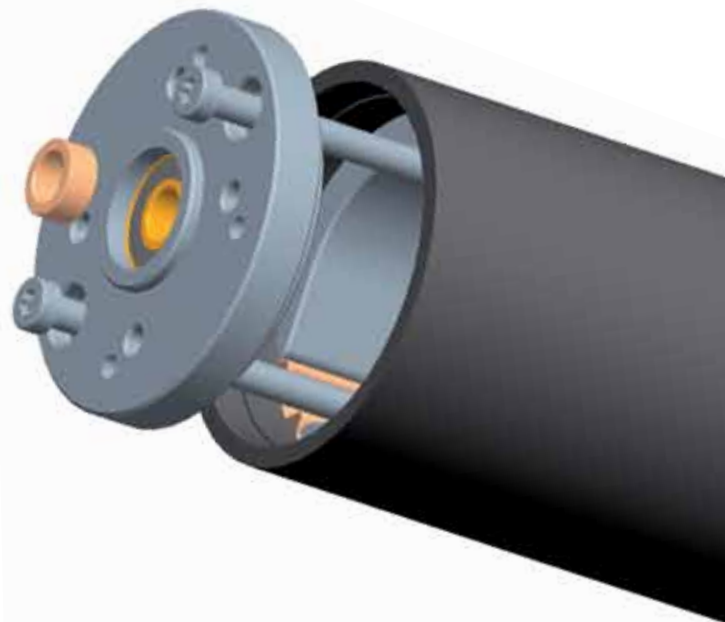

Exceptionally quiet

Systematic approach to eliminate noise

- At source
- From transmission
- From dispersion

Innovative design

- Choice of new materials
- Optimization of component assembly (centering, perpendicularity, parallelism, etc.)

A range of gearbox

in line with high performance motor

Service life up to 24,000 hours

- Its average service life, in continuous duty, is between 24,000 hours at no-load and 5000 hours at rated load

More than 80% efficiency

High performance magnetic circuit

- Optimum magnetic flux
- Magnets designed to optimize the detent torque

Optimal electromagnetic performance

- Energy losses on the winding
- Magnetic losses
- Minimal friction

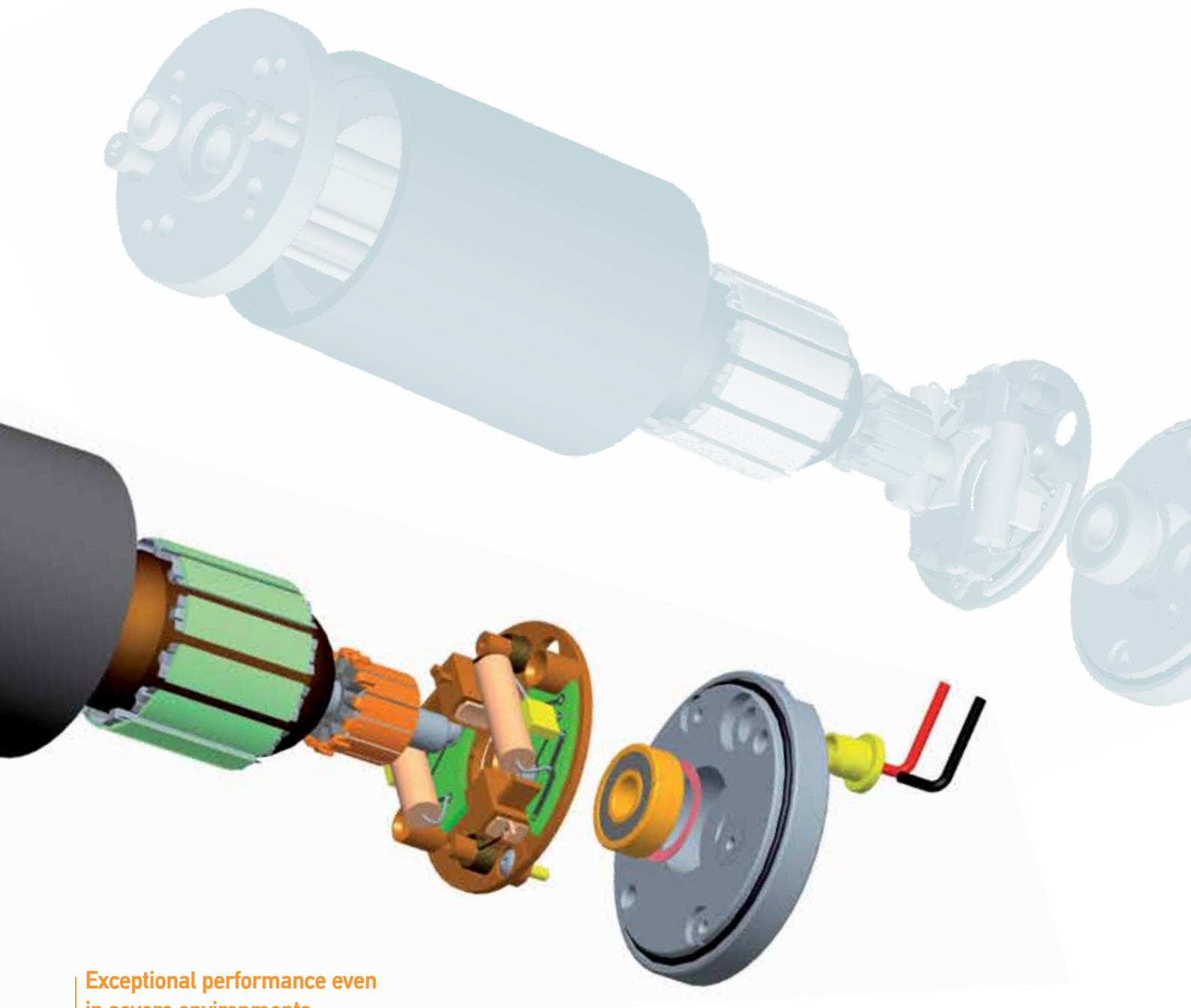

Exceptional performance even in severe environments

IP65 as standard

- Front and rear end caps redesigned to ensure a good seal, including wire exits
- IP 67 on request
- IP 69K on request

Approvals and conformities

- UL 1004 - CE - ROHS
- Medical (IEC 60601-1)
- Office automation (IEC 60950)
- Household appliances (IEC 60335)

DCmind Brush

Eco-design

Crouzet has been involved in eco-design for many years (ISO 14001 held since 1997).

Its production plants have some of the lowest existing impacts on the environment, and in addition, all Crouzet's product developments are constantly reducing their footprint on ecosystems.

The DCmind Brush motors range reduces this footprint to a third of more conventional manufacturing techniques.

ECOLOGICAL FOOTPRINT ON NATURAL ENVIRONMENTS:

Throughout a product's service life, from design through to the recycling stage, every manufactured product has an impact on ecosystems.

Reducing this footprint is a priority for any company that cares about the environment.

The diagram opposite compares the footprint of a conventional design with the new design.

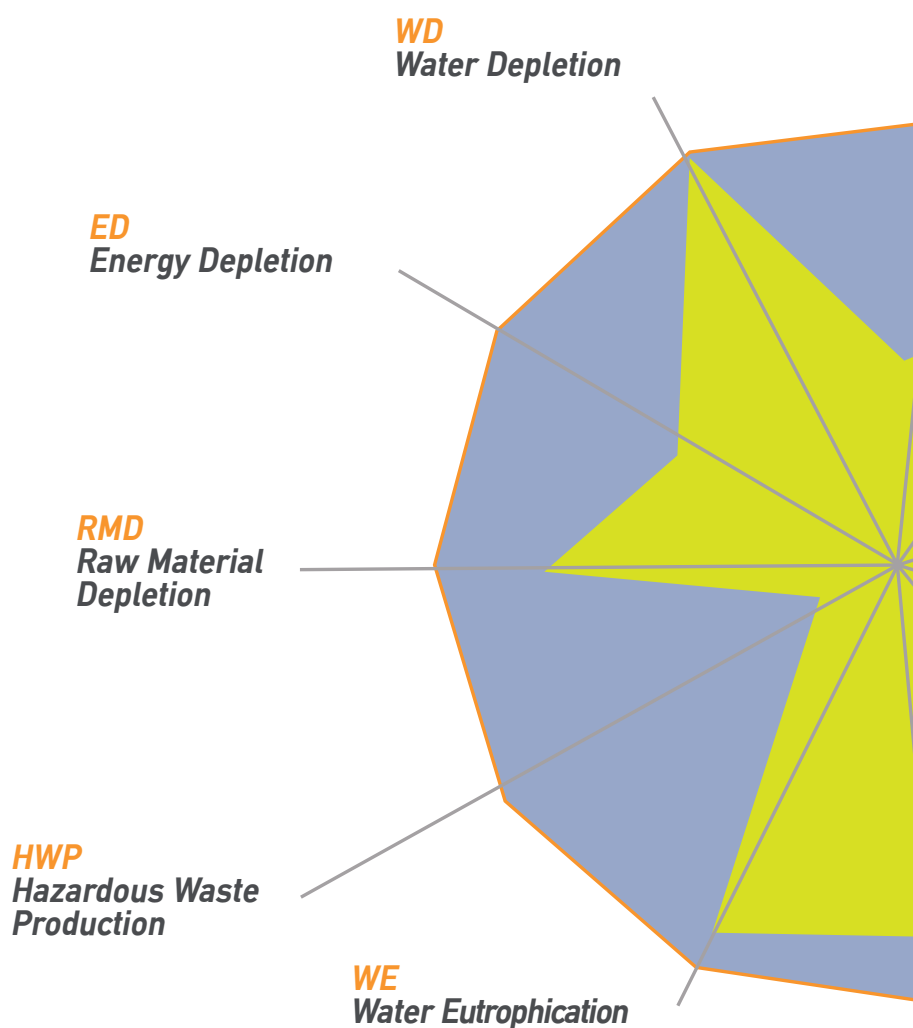

■ Footprint usually left on ecological environments by standard industrial design motors.



NOISE LEVEL:
 A noise level comparable to
 the sound of the wind
 rustling in the trees...

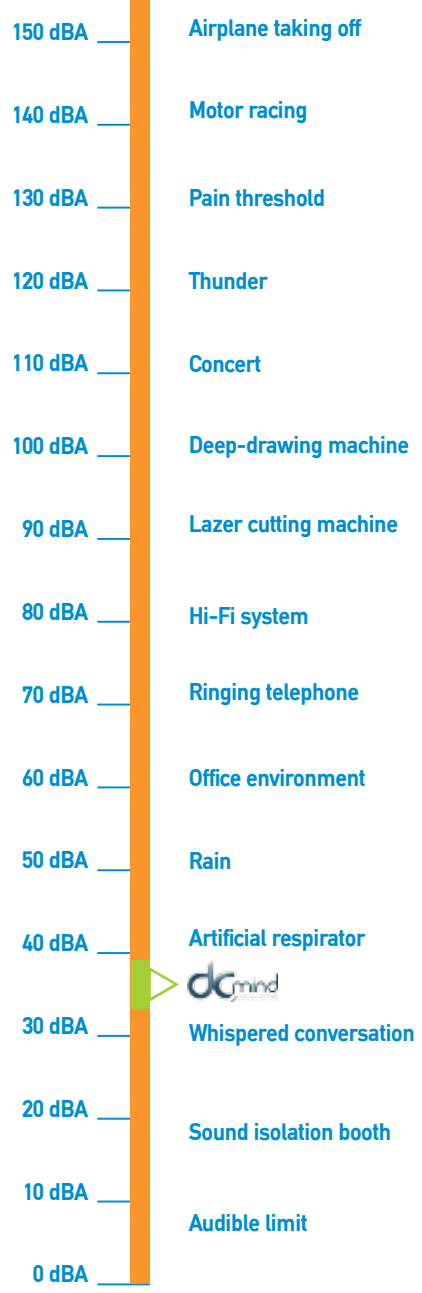
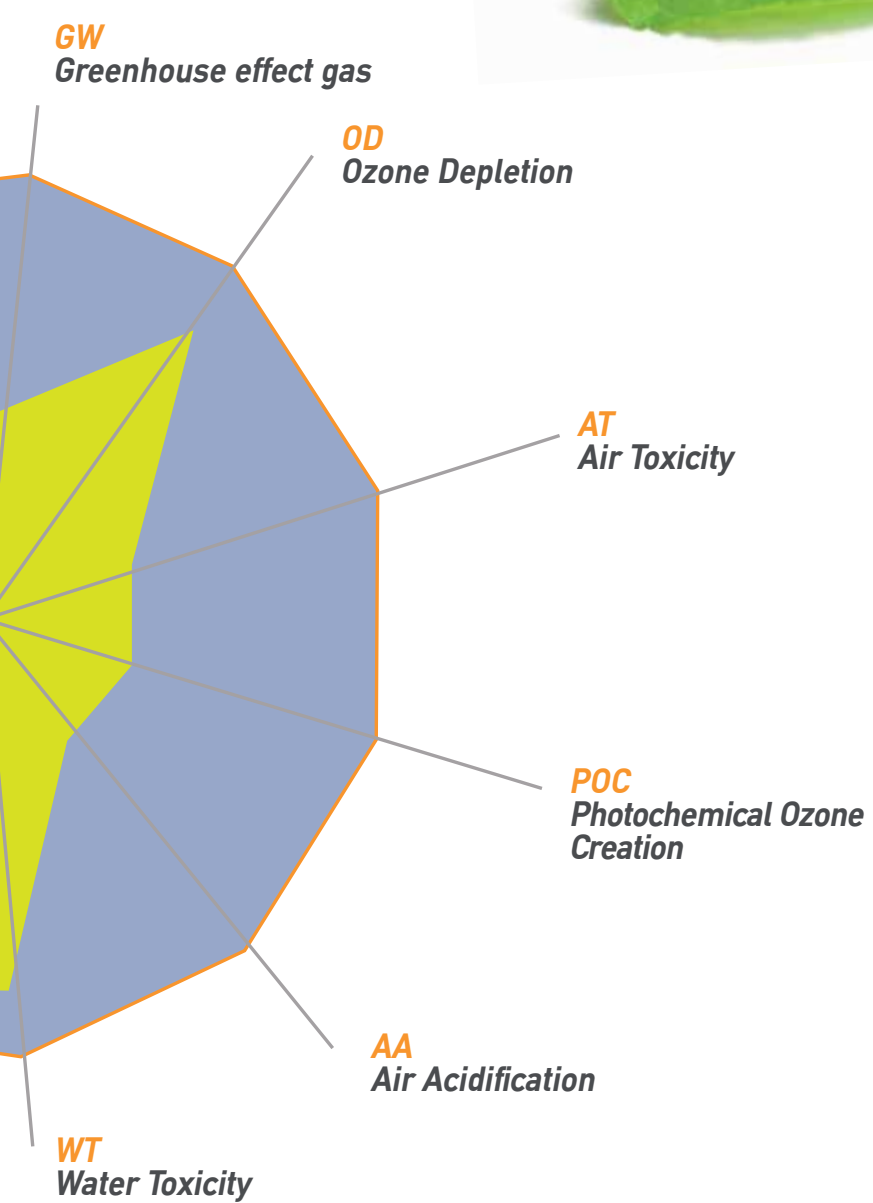

The new Crouzet design's ecological footprint.

DCmind Brush

Selection guide





To complement the current range of Crouzet motors and Geared Motors, the new generation of Brush Motors pays careful attention to machining the parts which make up the motor in order to reduce mechanical and electro-mechanical variations.

Extremely quiet, this new range is ideally suited to medical and laboratory applications.

GEARBOXES

MAX TORQUE (Nm)
Family
Type of gearbox

DIRECT DRIVE MOTORS

TYPE REFERENCE	OUTPUT POWER (W)	NOMINAL TORQUE (mNm)	NOMINAL SPEED (rpm)
Ø 42 mm			
 89810	15	50	2920
 89800	24	75	3100
 89850	35	110	3000
Ø 63 mm			
 89830	57	180	3000
 89890	104	290	3430

Motors 24 V $\overline{=}$

Accessories and adaptations

- Rear brake
- 1000-pulses 2-channels encoder
- Connectors
- Voltage, speed, power
- Shaft dimensions and material
- Motor length
- Other ratios and gearboxes
- Etc.



15	25	10
A1	B1	RAD10
Planetary Ø 42	Planetary Ø 52	90°

GEARED MOTORS

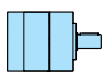

	8981A <u>x</u>	-	-
	8980A <u>x</u>	-	-
	8985A <u>x</u>	-	-
-	 8983B <u>x</u>	 89831 <u>y</u>	
-	 8989B <u>x</u>	 89891 <u>y</u>	

x = 1: IP65 | x = 5: brake | x = 9: encoder

y = 0: IP65 | y = 5: brake | y = 9: encoder

New adaptation possibilities

- Railway application (compliance with fire/smoke regulations)
- Isolation for use at 230 V
- Other colours

DCmind: DC direct-drive brush motors

→ Ø 42 mm - 20 W

- Silent motor
- 12 V and 24 V built in EMC filter class B
- Excellent efficiency
- Long life
- IP65
- In accordance with UL - CE - ROHS regulations



Part numbers

	12 V	24 V	48 V
Type	89810	89810	89810
Voltage	12 V $\overline{=}$	24 V $\overline{=}$	48 V $\overline{=}$
References			
Option: IP65 level	89810007	89810008	89810003
Option: holding brake 0.25 Nm, 24 V $\overline{=}$	89810507	89810508	89810503
Option: 2 channels encoder 1000 pulses/revolution, 5 V $\overline{=}$	89810907	89810908	89810903
No-load characteristics			
Speed (rpm)	4200	4000	4100
Absorbed current (A)	0.26	0.11	0.07
Nominal characteristics			
Speed (rpm)	2900	2920	2980
Torque (mNm)	50	50	50
Output power (W)	15	15	16
Absorbed current (A)	2.1	1	0.53
Efficiency (%)	60	64	61
Maximum efficiency characteristics			
Speed (rpm)	3500	3300	3400
Torque (mNm)	27	30	31
Output power (W)	10	10	11
Absorbed current (A)	1.26	0.6	0.35
Efficiency (%)	65	72	65
General characteristics			
Insulation conforming to IEC60085	Class E	Class E	Class E
Noise level (dBA)	35	35	35
Max. output power (W)	17	20	19
Starting torque (mNm)	158	190	180
Starting current (A)	6.1	3.3	1.7
Resistance (Ω)	2	7.3	28
Inductance (mH)	1.3	6	22
Torque constant (mNm/A)	27	56	109
Electrical time constant (ms)	0.7	0.8	0.8
Mechanical time constant (ms)	20	17	18
Inertia (g.cm ²)	75	75	75
Weight (g)	340	340	340
Commutator segments	8	8	8
Service life (h)	4000	4000	4000
Wires length (mm)	200	200	200
Ball bearing	✓	✓	✓
Comments			
IP65 level except for the output shaft. Encoder and brake options are IP20.			

Product adaptations, contact us



- Special output shaft
- Shaft with pinion, pulley, worm gear
- Special supply voltage
- Other wire length
- Optical or Hall effect encoder - 1 or 2 channels
- Specific motor mounting flange
- Special motor connectors
- IP67, IP69K

Curves

89810007 - 89810507 - 89810907

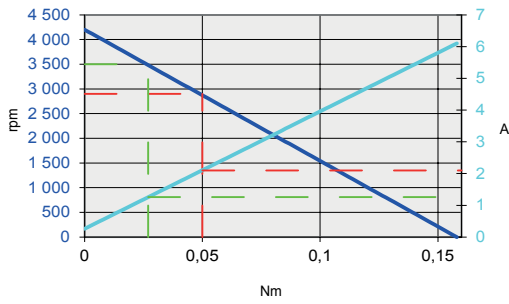

89810008 - 89810508 - 89810908

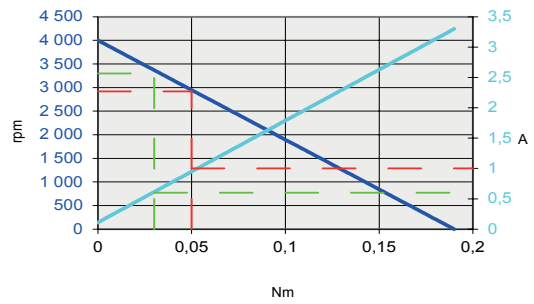

89810003 - 89810503 - 89810903

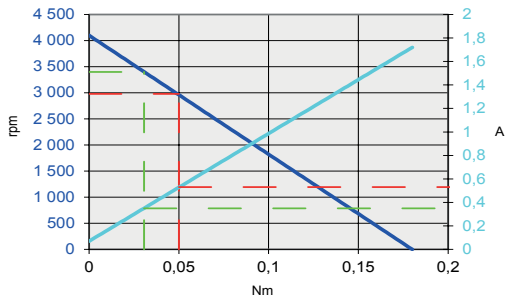

— Speed (rpm)
 — Current (A)
 — Torque at nominal
 — Torque at maximum efficiency

Dimensions (mm)

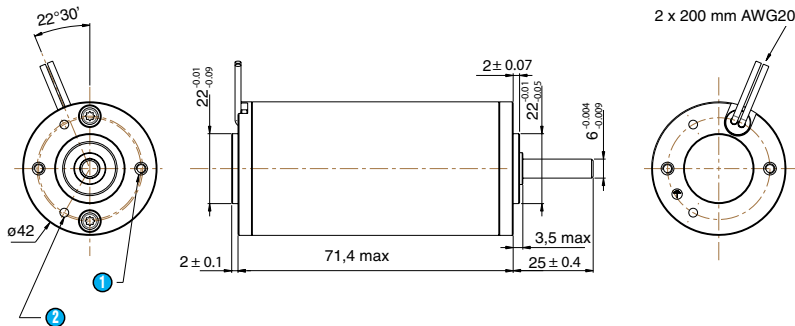

- ① 2 x M3 at 180° depth 5 over Ø 32
- ② 2 x Ø 2.75 at 120° depth 5 over Ø 32

Options

Holding brake 0.25 Nm

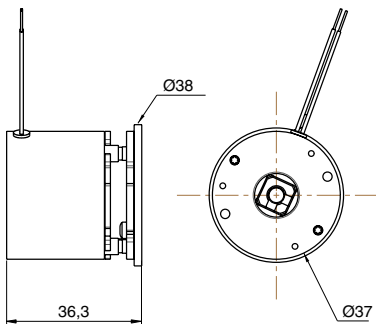

Encoder

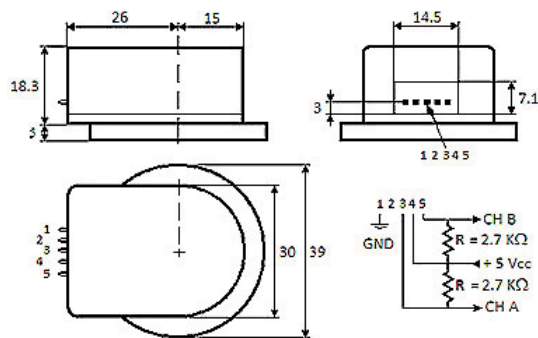

DCmind: DC direct-drive brush motors

→ Ø 42 mm - 36 W

- Silent motor
- 12 V and 24 V built in EMC filter class B
- Excellent efficiency
- Long life
- IP65
- In accordance with UL - CE - ROHS regulations



Part numbers

	12 V	24 V	48 V
Type	89800	89800	89800
Voltage	12 V ⁻⁻⁻	24 V ⁻⁻⁻	48 V ⁻⁻⁻
References			
Option: IP65 level	89800007	89800008	89800003
Option: holding brake 0.25 Nm, 24 V ⁻⁻⁻	89800507	89800508	89800503
Option: 2 channels encoder 1000 pulses/revolution, 5 V ⁻⁻⁻	89800907	89800908	89800903
No-load characteristics			
Speed (rpm)	4200	4000	3930
Absorbed current (A)	0.26	0.115	0.07
Nominal characteristics			
Speed (rpm)	3050	3100	3150
Torque (mNm)	75	75	75
Output power (W)	24	24	25
Absorbed current (A)	3	1.43	0.72
Efficiency (%)	67	71	72
Maximum efficiency characteristics			
Speed (rpm)	3620	3500	3450
Torque (mNm)	38	41	48
Output power (W)	14	15	17
Absorbed current (A)	1.6	0.84	0.49
Efficiency (%)	73	75	74
General characteristics			
Insulation conforming to IEC60085	Class E	Class E	Class E
Noise level (dBA)	35	35	35
Max. output power (W)	30	36	39
Starting torque (mNm)	276	344	377
Starting current (A)	10.3	6.1	3.3
Resistance (Ω)	1.2	3.9	14.5
Inductance (mH)	0.8	3	13
Torque constant (mNm/A)	27	57	115
Electrical time constant (ms)	0.7	0.8	0.9
Mechanical time constant (ms)	17	13	12
Inertia (g.cm ²)	110	110	110
Weight (g)	450	450	450
Commutator segments	8	8	8
Service life (h)	4000	4000	4000
Wires length (mm)	200	200	200
Ball bearing	✓	✓	✓
Comments			
IP65 level except for the output shaft. Encoder and brake options are IP20.			

Product adaptations, contact us



- Special output shaft
- Shaft with pinion, pulley, worm gear
- Special supply voltage
- Other wire length
- Optical or Hall effect encoder - 1 or 2 channels
- Specific motor mounting flange
- Special motor connectors
- IP67, IP69K

Curves

89800007 - 89800507 - 89800907

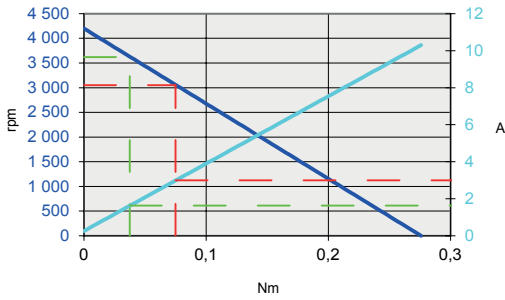

89800008 - 89800508 - 89800908

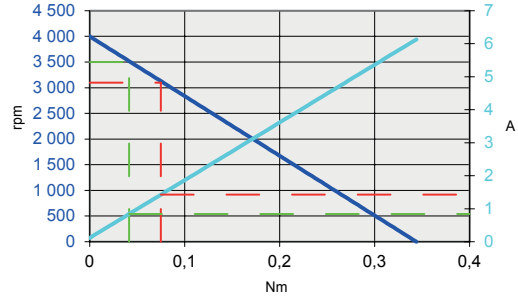

89800003 - 89800503 - 89800903

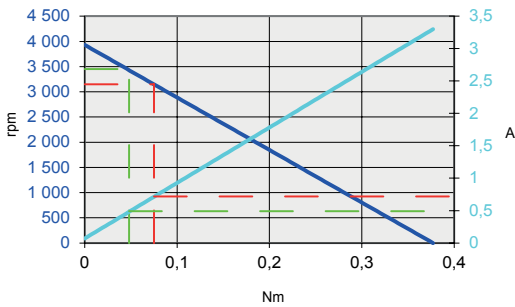

- Speed (rpm)
- Current (A)
- Torque at nominal
- Torque at maximum efficiency

Dimensions (mm)

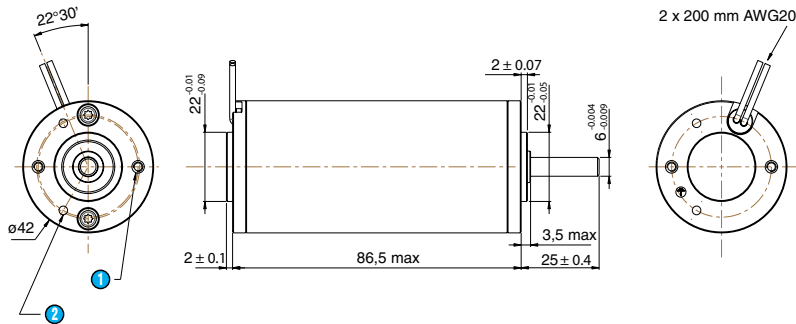

- ① 2 x M3 at 180° depth 5 over Ø 32
- ② 2 x Ø 2.75 at 120° depth 5 over Ø 32

Options

Holding brake 0.25 Nm

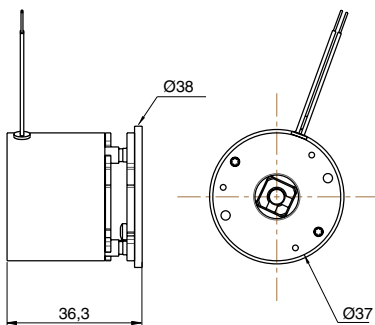

Encoder

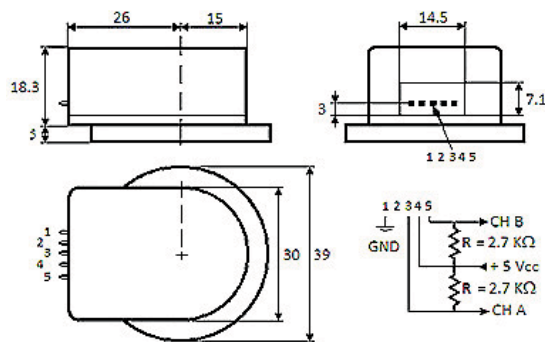

DCmind: DC direct-drive brush motors

→ Ø 42 mm - 51 W

- Silent motor
- 12 V and 24 V built in EMC filter class B
- Excellent efficiency
- Long life
- IP65
- In accordance with UL - CE - ROHS regulations



Part numbers

	12 V	24 V	48 V
Type	89850	89850	89850
Voltage	12 V ⁻⁻⁻	24 V ⁻⁻⁻	48 V ⁻⁻⁻
References			
Option: IP65 level	89850007	89850008	89850003
Option: holding brake 0.25 Nm, 24 V ⁻⁻⁻	89850507	89850508	89850503
Option: 2 channels encoder 1000 pulses/revolution, 5 V ⁻⁻⁻	89850907	89850908	89850903
No-load characteristics			
Speed (rpm)	4000	3750	3840
Absorbed current (A)	0.31	0.14	0.08
Nominal characteristics			
Speed (rpm)	3000	3000	3000
Torque (mNm)	110	110	110
Output power (W)	35	35	35
Absorbed current (A)	4.1	1.9	1
Efficiency (%)	70	76	72
Maximum efficiency characteristics			
Speed (rpm)	3500	3320	3400
Torque (mNm)	52	60	60
Output power (W)	19	21	21
Absorbed current (A)	2.1	1.1	0.58
Efficiency (%)	76	80	77
General characteristics			
Insulation conforming to IEC60085	Class E	Class E	Class E
Noise level (dBA)	35	35	35
Max. output power (W)	44	51	50
Starting torque (mNm)	420	520	500
Starting current (A)	15	8.4	4.2
Resistance (Ω)	0.8	2.9	11.4
Inductance (mH)	0.5	2	8
Torque constant (mNm/A)	29	63	120
Electrical time constant (ms)	0.6	0.7	0.7
Mechanical time constant (ms)	15	12	13
Inertia (g.cm ²)	160	160	160
Weight (g)	620	620	620
Commutator segments	8	8	8
Service life (h)	4000	4000	4000
Wires length (mm)	200	200	200
Ball bearing	✓	✓	✓
Comments			
IP65 level except for the output shaft. Encoder and brake options are IP20.			

Product adaptations, contact us



- Special output shaft
- Shaft with pinion, pulley, worm gear
- Special supply voltage
- Other wire length
- Optical or Hall effect encoder - 1 or 2 channels
- Specific motor mounting flange
- Special motor connectors
- IP67, IP69K

Curves

89850007 - 89850507 - 89850907

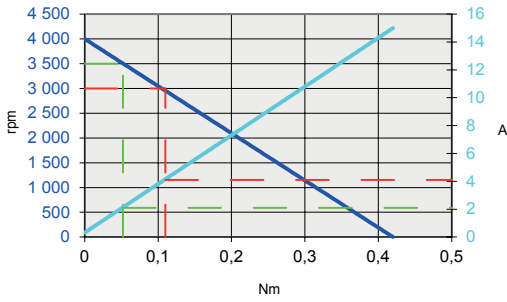

89850008 - 89850508 - 89850908

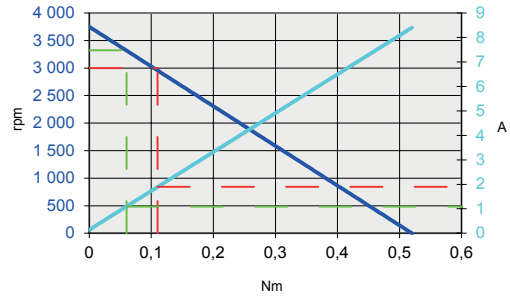

89850003 - 89850503 - 89850903

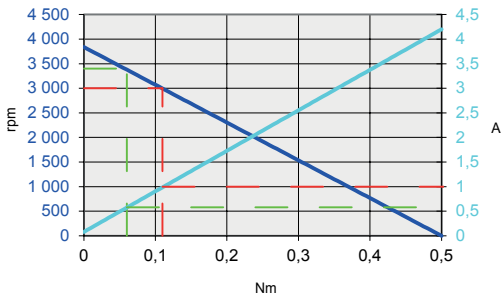

- Speed (rpm)
- Current (A)
- Torque at nominal
- Torque at maximum efficiency

Dimensions (mm)

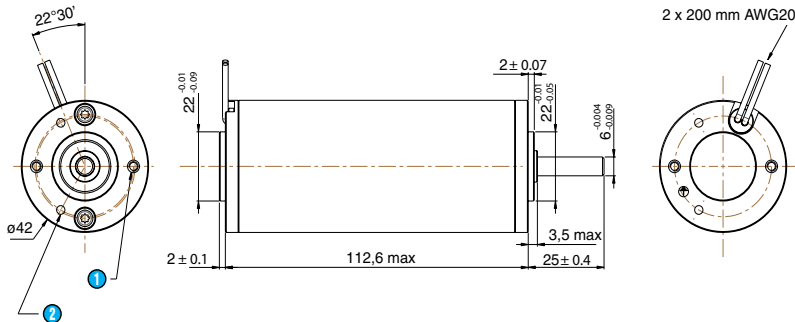

- ① 2 x M3 at 180° depth 5 over Ø 32
- ② 2 x Ø 2.75 at 120° depth 5 over Ø 32

Options

Holding brake 0.25 Nm

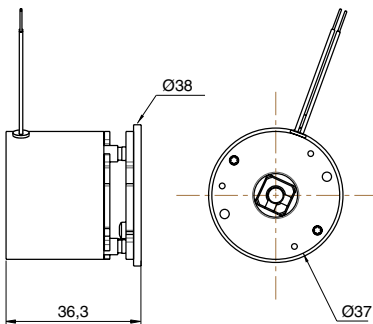

Encoder

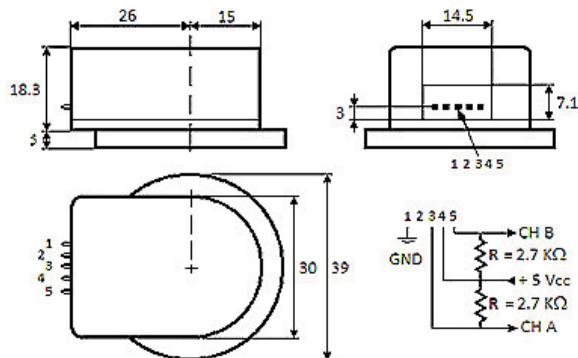

DCmind: DC direct-drive brush motors

→ Ø 63 mm - 102 W

- Silent motor
- 12 V and 24 V built in EMC filter class B
- Excellent efficiency
- Long life
- IP65
- In accordance with UL - CE - ROHS regulations



Part numbers

	12 V	24 V	48 V	90 V
Type	89830	89830	89830	89830
Voltage	12 V \overline{DC}	24 V \overline{DC}	48 V \overline{DC}	90 V \overline{DC}
References				
Option: IP65 level	89830011	89830012	89830003	89830004
Option: holding brake 0.5 Nm, 24 V \overline{DC}	89830511	89830512	89830503	89830504
Option: 2 channels encoder 1000 pulses/revolution, 5 V \overline{DC}	89830911	89830912	89830903	89830904
No-load characteristics				
Speed (rpm)	3830	3600	3550	3550
Absorbed current (A)	0.52	0.23	0.14	0.07
Nominal characteristics				
Speed (rpm)	2850	3000	3050	3000
Torque (mNm)	180	180	180	180
Output power (W)	54	57	57	57
Absorbed current (A)	6.5	3.1	1.54	0.83
Efficiency (%)	69	77	78	76
Maximum efficiency characteristics				
Speed (rpm)	3340	3240	3200	3200
Torque (mNm)	90	111	131	128
Output power (W)	31	38	44	43
Absorbed current (A)	3.5	1.97	1.15	0.61
Efficiency (%)	75	80	80	78
General characteristics				
Insulation conforming to IEC 60085	Class E	Class E	Class E	Class E
Noise level (dBA)	35	35	35	35
Max. output power (W)	70	102	114	109
Starting torque (mNm)	703	1080	1230	1177
Starting current (A)	24	17.2	9.7	5
Resistance (Ω)	0.5	1.4	4.9	18
Inductance (mH)	0.38	1.7	7	25
Torque constant (mNm/A)	30	64	129	237
Electrical time constant (ms)	0.8	1.2	1.4	1.4
Mechanical time constant (ms)	21	13	11	12
Inertia (g.cm ²)	380	380	380	380
Weight (g)	1200	1200	1200	1200
Commutator segments	12	12	12	12
Service life (h)	5000	5000	5000	5000
Wires length (mm)	200	200	200	200
Ball bearing	✓	✓	✓	✓
Comments				

IP65 level except for the output shaft. Encoder and brake options are IP20.

Product adaptations, contact us



- Special output shaft
- Shaft with pinion, pulley, worm gear
- Special supply voltage
- Other wire length
- Optical or Hall effect encoder - 1 or 2 channels
- Specific motor mounting flange
- Special motor connectors
- IP67, IP69K

DCmind: DC direct-drive brush motors

→ Ø 63 mm - 209 W

- Silent motor
- 24 V built in EMC filter class B
- Excellent efficiency
- Long life
- IP65
- In accordance with UL - CE - ROHS regulations



Part numbers

	24 V	48 V	90 V	120 V
Type	89890	89890	89890	89890
Voltage	24 V \overline{DC}	48 V \overline{DC}	90 V \overline{DC}	120 V \overline{DC}
References				
Option: IP65 level	89890011	89890003	89890004	89890005
Option: holding brake 0.5 Nm, 24 V \overline{DC}	89890511	89890503	89890504	89890505
Option: 2 channels encoder 1000 pulses/revolution, 5 V \overline{DC}	89890911	89890903	89890904	89890905
No-load characteristics				
Speed (rpm)	4000	3780	3700	3730
Absorbed current (A)	0.34	0.16	0.09	0.07
Nominal characteristics				
Speed (rpm)	3430	3370	3320	3350
Torque (mNm)	290	290	290	290
Output power (W)	104	102	101	102
Absorbed current (A)	5.4	2.53	1.34	1.01
Efficiency (%)	80	84	84	84
Maximum efficiency characteristics				
Speed (rpm)	3660	3480	3410	3430
Torque (mNm)	179	207	218	230
Output power (W)	69	75	78	83
Absorbed current (A)	3.5	1.9	1	0.82
Efficiency (%)	82	84	84	84
General characteristics				
Insulation conforming to IEC60085	Class E	Class E	Class E	Class E
Noise level (dBA)	35	35	35	35
Max. output power (W)	209	265	269	281
Starting torque (mNm)	2000	2680	2780	2875
Starting current (A)	35.3	22.2	12.1	9.4
Resistance (Ω)	0.7	2.2	7.4	12.8
Inductance (mH)	0.73	3.3	12	21
Torque constant (mNm/A)	57	122	232	308
Electrical time constant (ms)	1.1	1.5	1.6	1.6
Mechanical time constant (ms)	13	9	9	9
Inertia (g.cm ²)	650	650	650	650
Weight (g)	1600	1600	1600	1600
Commutator segments	12	12	12	12
Service life (h)	5000	5000	5000	5000
Wires length (mm)	200	200	200	200
Ball bearing	✓	✓	✓	✓
Comments				

IP65 level except for the output shaft. Encoder and brake options are IP20.

Product adaptations, contact us



- Special output shaft
- Shaft with pinion, pulley, worm gear
- Special supply voltage
- Other wire length
- Optical or Hall effect encoder - 1 or 2 channels
- Specific motor mounting flange
- Special motor connectors
- IP67, IP69K

Curves

89890011 - 89890511 - 89890911

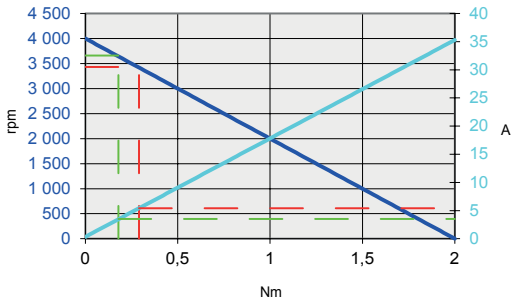

89890003 - 89890503 - 89890903

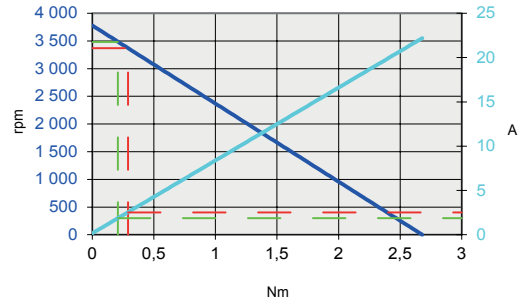

89890004 - 89890504 - 89890904

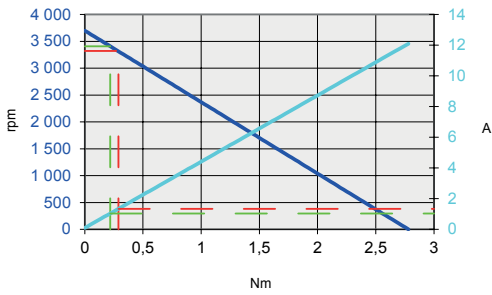

89890005 - 89890505 - 89890905

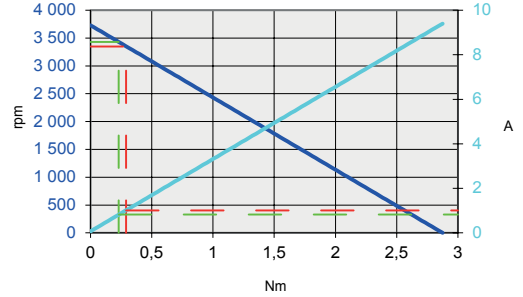

- Speed (rpm)
- Current (A)
- Torque at nominal
- Torque at maximum efficiency

Dimensions (mm)

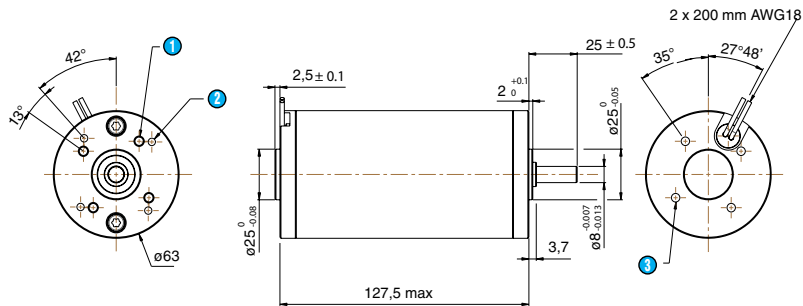

- ① 4 x M5 at 90° depth 10 over \varnothing 40
- ② 4 x \varnothing 3.65 at 90° depth 8 over \varnothing 48
- ③ 4 x M5 at 90° depth 7 over \varnothing 40

Options

Holding brake 0.5 Nm

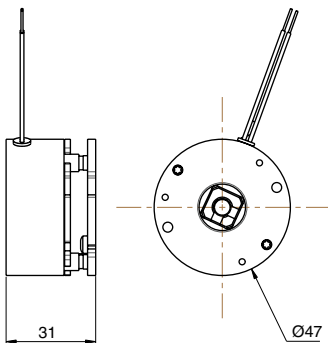

Encoder

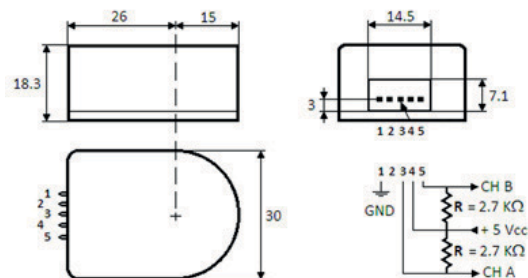

Gearboxes for DCmind brush range

→ 3 to 25 Nm

- Planetary and worm gearboxes, very silent versions
- Shafts on ball bearings
- Long service life

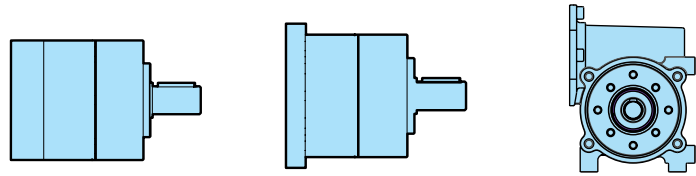

Part numbers

Gearboxes	A1			B1			RAD10
Family	A1			B1			RAD10
Type of gearbox	Planetary ø 42			Planetary ø 52			Worm gear
Associated motors	Gear motor reference			Gear motor reference			Gear motor reference
89810 IP65 / Holding brake / Encoder	8981 A1 / A5 / A9						
89800 IP65 / Holding brake / Encoder	8980 A1 / A5 / A9						
89850 IP65 / Holding brake / Encoder	8985 A1 / A5 / A9						
89830 IP65 / Holding brake / Encoder				8983 B1 / B5 / B9			8983 10 / 15 / 19
89890 IP65 / Holding brake / Encoder				8989 B1 / B5 / B9			8989 10 / 15 / 19
General characteristics							
Number of stages	1	2	3	1	2	3	1
Maximum permitted torque (Nm)	3	7.5	15	4	12	25	10
Efficiency	0.8	0.75	0.7	0.8	0.75	0.7	0.6 → 0.3
Axial dynamic load (daN)	5	8	11	6	10	15	10
Radial dynamic load (daN)	16	23	30	20	32	45	15
Weight (kg)	0.3	0.4	0.5	0.7	0.9	1.1	0.6
Standard reduction ratios	9	45	302	7-9	28-45	302	5 - 10 - 20 - 30 - 50
Other ratios possible	58 - 137 - 232 - 393			58 - 137 - 192 - 232 - 393			15 - 100
Operating temperature	-30 → +70°C			-30 → +70°C			-10 → +75°C
Typical noise level	45 dBA			45 dBA			45 dBA
Comments							

Planetary gearboxes:

To maintain a very low noise level, the motor pinion is precision machined on motor shaft to obtain optimum concentricity and parallelism. The gears in the first stage are helical-cut and made from a composite material. This design significantly improves gear life by reducing wear due to misalignment, increases gearbox efficiency and ensures a very low noise level even with the gearbox under load.

Worm gearbox:

This gearbox combines a tempered steel worm gear with a hardened bronze helical wheel, a combination that ensures a long service life. The helical wheel rotates in a grease reservoir to provide an excellent slip coefficient and dissipate heat. O-rings and lip seals equipped with garter springs are used to ensure sealing the gearbox output shaft.

The gearbox casing is made of aluminium to maximize heat dissipation.

However, because of the high power rating of this gearbox and the lower efficiency inherent in ratio worm gearboxes, care must be taken not to exceed a temperature of 75°C on the gearbox casing during operation.

The output shaft configuration can be right, left, or a dual shaft (shaft output on both sides).

Product adaptations, contact us



- Special shafts
- Other reduction ratios
- Other fixing holes
- Special mounting flange

Dimensions (mm)

Planetary gearbox $\phi 42$ type A1

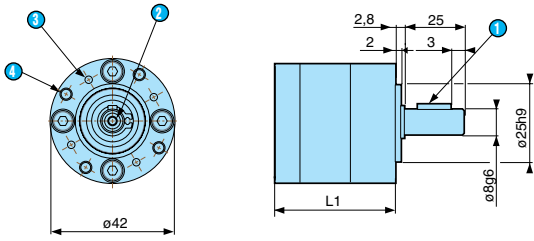

- 1 Parallel key 3 x 3 x 16 DIN6885
- 2 M3, depth 9
- 3 4 x M3 at 90°, depth 7 over $\phi 32$
- 4 4 x M4 at 90°, depth 10 over $\phi 36$

L1 1 stage: 48.5 max.
 L1 2 stages: 61.6 max.
 L1 3 stages: 74.7 max.

Planetary gearbox $\phi 52$ type B1

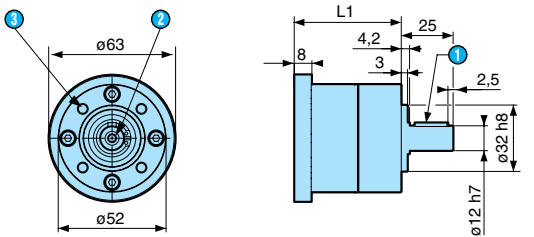

- 1 Parallel key 4 x 4 x 16 DIN6885
- 2 M4, depth 10
- 3 4 x M5 at 90°, depth 10 over $\phi 40$

L1 1 stage: 56.1 max.
 L1 2 stages: 70.3 max.
 L1 3 stages: 84.5 max.

Worm gearbox RAD10

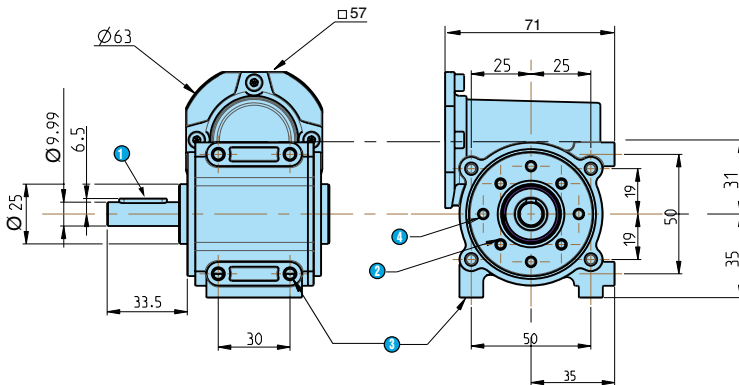

- 1 Parallel key 4 x 4 x 20 DIN6885
- 2 4 x M4, depth 8 over $\phi 36$
- 3 8 x M5, depth 8
- 4 4 x $\phi 3.8$ depth 10 over $\phi 40$

The left-hand and right-hand sides of the gearbox are identical.

DC geared DCmind brush

Dimensions (mm)

8981A1 - 8980A1 - 8985A1

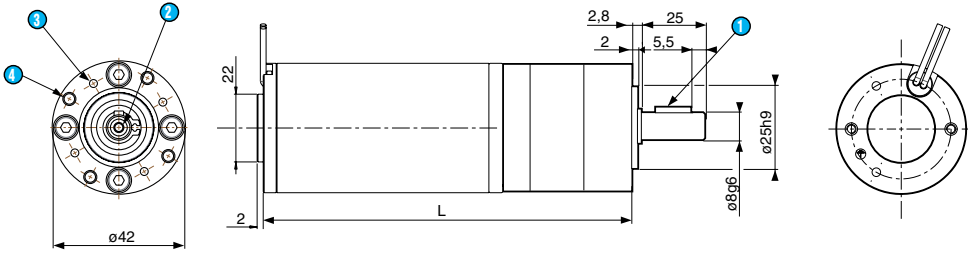

8981A1

L 1 stage: 119.9 max.
L 2 stages: 133 max.
L 3 stages: 146.1 max.

8980A1

L 1 stage: 135 max.
L 2 stages: 148.1 max.
L 3 stages: 161.2 max.

8985A1

L 1 stage: 161.1 max.
L 2 stages: 174.2 max.
L 3 stages: 187.3 max.

- 1 Parallel key 3 x 3 x 16 DIN6885
- 2 M3, depth 9
- 3 4 x M3 at 90°, depth 7 over Ø 32
- 4 4 x M4 at 90°, depth 10 over Ø 36

8983B1 - 8989B1

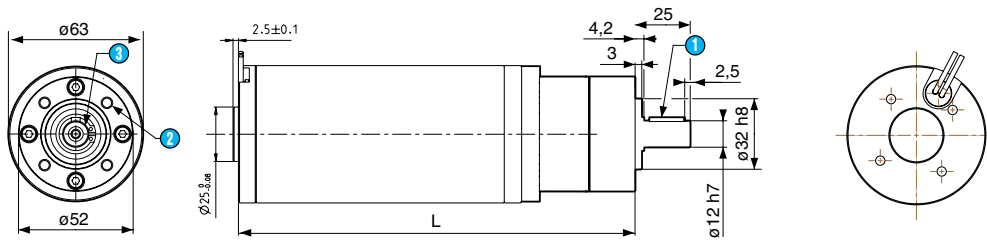

8983B1

L 1 stage: 159.1 max.
L 2 stages: 173.3 max.
L 3 stages: 187.5 max.

8989B1

L 1 stage: 183.6 max.
L 2 stages: 197.8 max.
L 3 stages: 212 max.

- 1 Parallel key 4 x 4 x 16 DIN6885
- 2 4 x M5 at 90°, depth 10 over Ø 30
- 3 M4, depth 10

898310 - 898910 (left side shaft output)

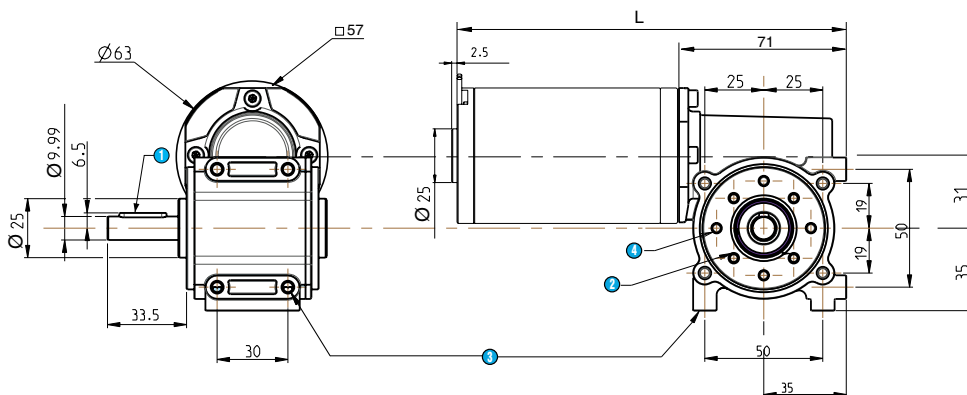

898310

L: 174.2 max.

898910

L: 198.7 max.

- 1 Parallel key 4 x 4 x 20 DIN6885
- 2 4 x M4, depth 8 over Ø 36
- 3 8 x M5, depth 8
- 4 4 x 3.8, depth 10 over Ø 40



Custom Sensors & Technologies (CST) is a specialist in sensing, control and motion products.

Through its brands, BEI Kimco, BEI Sensors, BEI PSSC, Crouzet, Crydom, Kavlico, Newall and Systron Donner Inertial, CST offers customizable, reliable and efficient components for mission-critical systems in Aerospace & Defence, Transportation, Energy & Infrastructures, Commercial & Industrial OEMs, Medical, Food and Beverage and Building Equipment markets.

Focused on premium value offers and committed to excellence, CST, with 4700 employees worldwide and sales of \$660M US in 2011, is the dependable and adaptable partner for the most demanding customers.

www.cstsensors.com

Distributed by:



Crouzet Automatismes SAS

2 rue du Docteur Abel - CS 60059
26902 Valence CEDEX 9
FRANCE

www.crouzet.com

CRZ BR 55/D EN
Ref. 6752204 EN
10/2012

AMERICA



BRAZIL
Custom Sensors & Technologies
Crouzet Latinoamerica
Alameda Rio Negro
1030 - cj 1803 - Alphaville -
Barueri SP - CEP 06454-000
BRASIL
Tel. : +55 (11) 2505 7500
Fax : +55 (11) 2505 7507
E-mail : info@cst-latinoamerica.com
www.crouzet.com.br
www.cst-latinoamerica.com



USA/CANADA
Custom Sensors & Technologies - Crouzet
1499 Poinsettia Ave Suite 160
Vista, CA, 92081
USA
Tel. : +1 (800) 677 5311
Fax : +1 (800) 677 3865
E-mail : CRZ-NA.Motors@crouzet.com
www.crouzet.com



MEXICO
Custom Sensors & Technologies - Crouzet
Calzada Zavaleta 2505-C
Santa Cruz Buenavista -
Puebla. 72150 MEXICO
Tel. : +1 (222) 409 7000
Fax : +1 (222) 409 7810
E-mail : mexico@cstsensors.com
www.crouzet.com



OTHER COUNTRIES
Custom Sensors & Technologies
Crouzet Latinoamerica
Alameda Rio Negro
1030 - cj 1803 - Alphaville -
Barueri SP - CEP 06454-000
BRASIL
Tel. : +55 (11) 4195 1834
Fax : +55 (11) 4191 9136
E-mail : info@cst-latinoamerica.com
www.crouzet.com.br
www.cst-latinoamerica.com

**EUROPE
MIDDLE EAST
AFRICA**



BELGIUM
Crouzet NV/SA
Dieweg 3 B
B - 1180 Uccle
BELGIUM
Tel. : +32 (0) 2 462 07 30
Fax : +32 (0) 2 461 00 23
E-mail : com-be@crouzet.com
www.crouzet.be



FRANCE
Crouzet Automatismes SAS
2 rue du Docteur Abel - CS 60059
26902 Valence CEDEX 9
FRANCE
Tel. : +33 (0) 4 75 44 88 44
Fax : +33 (0) 4 75 55 98 03
E-mail : com-fr@crouzet.com
www.crouzet.fr

Customer service
Tel. : +33 (0) 4 75 80 21 01
Fax : +33 (0) 4 75 82 89 00

Creation-Design: Communication Crouzet, Coxinelis
Editing-Publishing: Communication Crouzet, Coxinelis, TBWA
Photos-Graphics: Ginko
Printing: Imprimerie des Deux Ponts



GERMANY/AUSTRIA
Crouzet GmbH
Otto-Hahn-Str. 3, 40721 Hilden
Postfach 203, 40702 Hilden
DEUTSCHLAND
Tel. : +49 (0) 21 03 9 80-151
Fax : +49 (0) 21 03 9 80-222
E-mail : info-direkt@crouzet.com
www.crouzet.de



ITALY
Crouzet Componenti s.r.l.
Via Viganò De Vizzi, 93/95
20092 Cinisello Balsamo (MI)
ITALIA
Tel. : +39 (02) 66 599 230
Fax : +39 (02) 66 599 238
E-mail : crz-it-motori@crouzet.com
www.crouzet.it



SPAIN/PORTUGAL
Crouzet Ibérica
Avda. Dels Vents, 9-13
Esc.A 3ª Planta Oficina 2B
08917 Badalona
ESPAÑA
Tel. : +34 (93) 484 39 70
Fax : +34 (93) 484 39 73
E-mail : es-consultas@crouzet.es
www.crouzet.es



THE NETHERLANDS
Crouzet BV
Industrieweg 17
2382 NR Zoeterwoude
NEDERLAND
Tel. : +31 (0) 71-581 20 30
Fax : +31 (0) 71-541 35 74
E-mail : com-nl@crouzet.com
www.crouzet.nl



UNITED KINGDOM
Crouzet Ltd
8 Cedarwood
Chineham Business Park
Crockford Lane
Basingstoke, Hampshire
RG24 8WD
UNITED KINGDOM
Tel. : +44 (0)1256 318 900
Fax : +44 (0)1256 318 901
E-mail : info@crouzet.co.uk
www.crouzet.co.uk



SWITZERLAND
Crouzet AG
Gewerbepark - Postfach 56
5506 Mägenwil
SCHWEIZ
Tel. : +41(0) 62 887 30 30
Fax : +41(0) 62 887 30 40
E-mail : info-direkt@crouzet.com
www.crouzet.ch



OTHER COUNTRIES
Crouzet Automatismes SAS
2 rue du Docteur Abel - CS 60059
26902 Valence CEDEX 9
FRANCE
Tel. : +33 (0) 475 802 102
Fax : +33 (0) 475 448 126
E-mail : com-ex@crouzet.com
www.crouzet.com

**ASIA
PACIFIC**

CHINA & HONG KONG
Custom Sensors & Technologies Asia (Shanghai) Limited - Crouzet
13th floor, Chang Feng
International Tower, 89 Yunling
Road (East), Putuo District
Shanghai 200062
CHINA
Tel. : +86 (21) 6065 6699
Fax : +86 (21) 6065 7749
E-mail : china@cstsensors.com
www.crouzet.cn
www.cstsensors.com

INDIA
CST Sensors India Pvt Ltd
4th Floor,
Trident Towers, No 23,
100 Feet Ashoka Pillar Road,
2nd Block, Jaynagar
Bangalore 560 011
INDIA
Tel. : +91 (0) 80 4113 2204/05
Fax : +91 (0) 80 4113 2206
E-mail : india@cstsensors.com
www.crouzet.co.in
www.cstsensors.com

TAIWAN & JAPAN
Custom Sensors & Technologies - Crouzet
2F, No. 39, Ji-Hu Road
Nei-Hu Dist. - Taipei 114
TAIWAN
Tel. : +886 (0)2 8751 6388
Fax : +886 (0)2 2657 8725
E-mail : taiwan@cstsensors.com
www.crouzet.com
www.cstsensors.com

KOREA
Custom Sensors & Technologies - Crouzet
14F, Kbiz DMC Tower.
189, Seongam-ro
Mapo-gu,
Seoul 121-904
SOUTH KOREA
Tel. : +82 (0)2 2629 8312
Fax : +82 (0)2 2629 8310
E-mail : korea@cstsensors.com
www.crouzet.com
www.cstsensors.com

SOUTH EAST ASIA & PACIFIC
Custom Sensors & Technologies - Crouzet
2F, No. 39, Ji-Hu Road
Nei-Hu Dist. - Taipei 114
TAIWAN
Tel. : +886 (0)2 8751 6388
Fax : +886 (0)2 2657 8725
E-mail : eap@cstsensors.com
www.crouzet.com
www.cstsensors.com

Warning:
The product information contained in this catalogue is given purely as information and does not constitute a representation, warranty or any form of contractual commitment. CROUZET Automatismes and its subsidiaries reserve the right to modify their products without notice. It is imperative that we should be consulted over any particular use or application of our products and it is the responsibility of the buyer to establish, particularly through all the appropriate tests, that the product is suitable for the use or application. Under no circumstances will our warranty apply, nor shall we be held responsible for any application (such as any modification, addition, deletion, use in conjunction with other electrical or electronic components, circuits or assemblies, or any other unsuitable material or substance) which has not been expressly agreed by us prior to the sale of our products.

