

Reversible synchronous geared motors

→ 0.5 Nm 2.7 Watts

- Mechanical strength : 0.5 Nm
- Constant speed, dependent on supply frequency
- Wide range of speeds available
- Direction of rotation controlled by dephasing capacitor
- Permanent magnet rotor
- UL, CSA, VDE approved, comply with IEC standards.



Specifications

Type	2.7 Watts		2.7 Watts	
Standard motor speed (rpm)	82 514 0		82 514 5	
Voltage / Frequency	250 230-240 V - 50 Hz		500 230-240 V - 50/60 Hz	
Output speed (250 RPM)	Output speed (500 RPM)	Ratios		
25.00 rpm	50.00 rpm	10	●	●
20.00 rpm	40.00 rpm	25/2	●	●
12.50 rpm	25.00 rpm	20	●	●
10.00 rpm	20.00 rpm	25	●	●
5.00 rpm	10.00 rpm	50	●	●
4.00 rpm	8.00 rpm	125/2	●	●
2.50 rpm	5.00 rpm	100	●	●
2.00 rpm	4.00 rpm	125	●	●
1.25 rpm	2.50 rpm	200	●	●
1.00 rpm	2.00 rpm	250	●	●
0.50 rpm	1.00 rpm	500	●	●
General characteristics				
Motor	82 510 0		82 510 5	
Gearbox	81 021 0		81 021 0	
Base speed of motor (rpm)	250		500	
Maximum permitted continuous rated gearbox output torque for 1 million revolutions of gearbox output shaft (Nm)	0.5		0.5	
Axial load static (daN)	1		1	
Radial load static (daN)	8		8	
Absorbed power (W)	2.7		2.7	
Motor output (W)	0.31		0.52	
Maximum temperature rise (°C)	50		60	
Ambient temperature (°C)	-5 → +70		-5 → +60	
Weight (g)	140		140	
Wires length mm (approximately)	250		250	
Protection rating	IP40		IP40	

Product adaptations

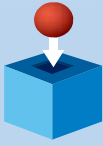

- Special supply voltages
- Special cable lengths
- Special connectors
- Special output shafts
- Special gearbox ratios
- Special gear wheel material
- Special output bearings

Curves

Graph of torque versus speed 82 514 0

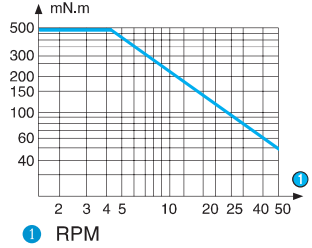

Graph of torque versus speed 82 514 5

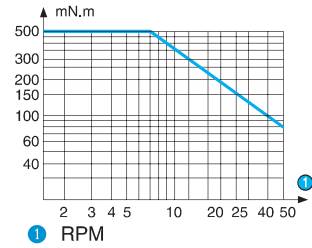

To order, see page 13

Accessories

Voltages/Frequencies	μF	V	Code
Capacitors motor 82 510 0			
230-240 V - 50 Hz	$0.33 \pm 10 \%$	400	26 231 801
115 V - 50/60 Hz	$0.27 \pm 10 \%$	250	26 231 851
24 V - 50 Hz	$8.2 \pm 10 \%$	70	26 231 711
24 V - 60 Hz	$6.8 \pm 10 \%$	63	26 231 708
Capacitors motor 82 510 5			
230-240 V 50/60 Hz	$0.39 \pm 10 \%$	630	21 231 924
115 V 50/60 Hz	$0.39 \pm 10 \%$	630	26 231 924
24 V 50/60 Hz	$8.2 \pm 10 \%$	70	26 231 711

Dimensions

82 514 0 - 82 514 5

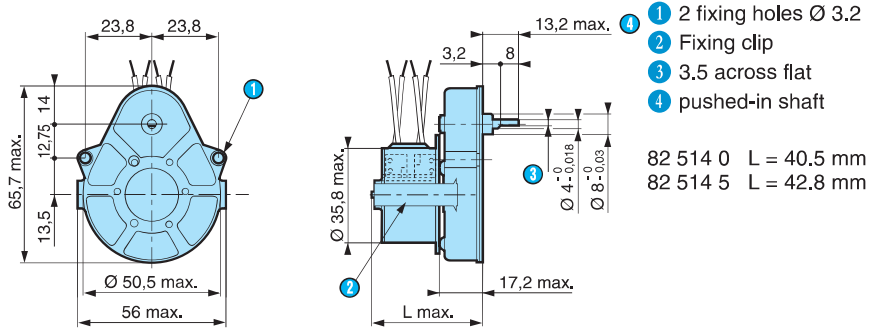

82 514 0 L = 40.5 mm
82 514 5 L = 42.8 mm

Options

Shaft 79 200 967

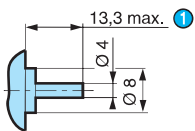

1 (pushed-in shaft ←)

Shaft 79 200 779

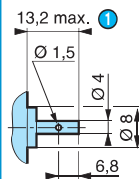

1 (pushed-in shaft ←)

Shaft 70 999 421 SP1295-10

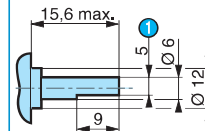

1 5 across flat

Connections

In parallel

Motors 82 510 0 - 82 510 5

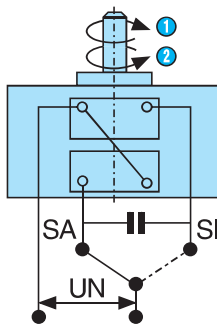

1 SA : Clockwise
2 SI : Anti-clockwise

In series

Motors 82 510 0 and 82 510 5
only 230 V - 240 V 50 Hz version

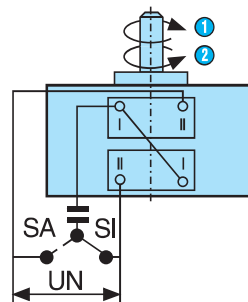

1 SA : Clockwise
2 SI : Anti-clockwise

Other information

The speed of a motor powered by a 60 Hz supply is 20 % higher than that of a motor powered by a 50 Hz supply.