

# Reversible synchronous geared motors

→ 5 Nm 3.5 and 7.2 Watts

- Mechanical strength : 5 Nm
- Constant speed, dependent on supply frequency
- Direction of rotation controlled by dephasing capacitor
- Permanent magnet rotor
- UL, CSA, VDE approved ; comply with IEC standards



## Specifications

Type  
Voltage / Frequency  
Base speed of motor (rpm)

**3.5 Watts**  
80 527 4  
230-240 V / 50 Hz  
375

**7.2 Watts**  
80 547 0  
230-240 V / 50 Hz  
250

Output speed (250 RPM)	Output speed (375 RPM)	Ratios
20 rpm	30 rpm	12.5
10 rpm	15 rpm	25
8 rpm	12 rpm	31.25
6 rpm	9 rpm	41.66
4 rpm	10 rpm	62.5
3 rpm	4.5 rpm	83.33
2 rpm	3 rpm	125
1 rpm	1.5 rpm	250
0.5 rpm	0.75 rpm	500
0.33 rpm	0.5 rpm	750
0.1 rpm	0.15 rpm	2500

●	80 547 024
●	80 547 015
●	●
●	80 547 016
●	80 547 017
●	80 547 018
●	80 547 019
●	80 547 020
●	80 547 021
●	●
●	●

### General characteristics

Motor	82 520 4	82 540 0
Gearbox	81 037 0	81 037 0
Maximum permitted continuous rated gearbox output torque for 1 million revolutions of gearbox output shaft (Nm)	5	5
Axial load static (daN)	2	2
Radial load static (daN)	3	3
Absorbed power (W)	3.5	7.2
Motors output (W)	1.12	2.65
Maximum temperature rise (°C)	50	55
Ambient temperature (°C)	-10 → +70	-10 → +70
Weight (g)	530	860
Wires length mm (approximately)	250	250
Protection rating	IP40	IP40

## Product adaptations

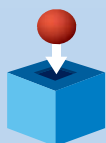

- Special supply voltages
- Special cable lengths
- Special connectors
- Special output shafts
- Special gearbox ratios
- Special gear wheel material
- Special output bearings

## Curves

Torque/speed curves 80 527 4

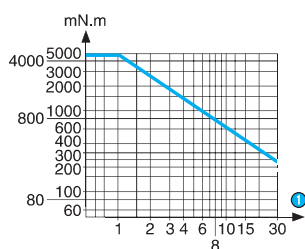

① RPM

Torque/speed curves 80 547 0

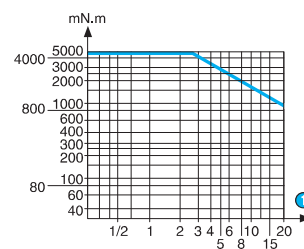

① RPM

To order, see page 13

## Accessories

Voltages/Frequencies	$\mu\text{F}$	V	Code
Capacitors for motors 82 520 4			
230/240 V - 50 Hz	$0,12 \pm 10 \%$	600	26 231 903
115 V - 60 Hz	$0,39 \pm 5 \%$	630	26 231 924
24 V - 50 Hz	$15 \pm 5 \%$	70	26 231 728
24 V - 60 Hz	$12 \pm 5 \%$	63	26 231 145
Capacitors for motor 82 540 0			
230-240 V 50 Hz	$0,22 \pm 5 \%$	630	26 231 909
115 V - 60 Hz	$0,56 \pm 5 \%$	400	26 231 822
24 V - 50 Hz	$22 \pm 10 \%$	63	26 231 703
24 V - 60 Hz	$15 \pm 5 \%$	70	26 231 728

## Dimensions

80 527 4 - 80 547 0

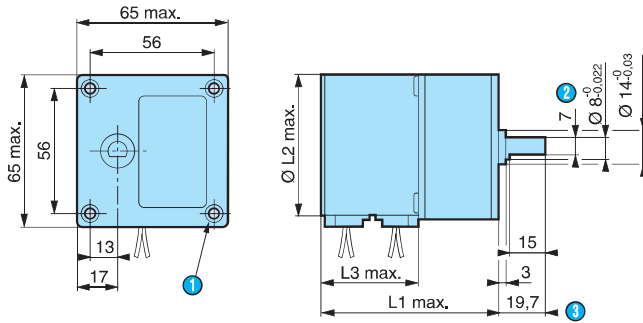

- ① 4 holes M4 depth 12
- ② 7 acroos flat
- ③ (pushed-in shaft ←)

80 527 4 L1 = 59,2 mm  $\varnothing$  L2 = 51,3 mm L3 = 25,6 mm  
 80 547 0 L1 = 76,6 mm  $\varnothing$  L2 = 65,3 mm L3 = 43 mm

## Options

Shaft 79 206 478

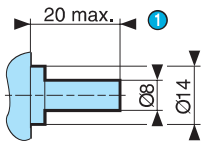

- ① (pushed-in ←)

## Connections

In parallel

Motors 82 520 4 - 82 540 0

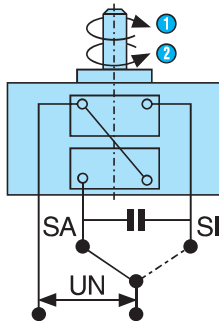

- ① SA : clockwise
- ② SI : anti-clockwise

## Other information

The speed of a motor powered by a 60 Hz supply is 20 % higher than that of a motor powered by a 50 Hz supply.