

Stepper gearmotor Data sheet

82 924 059
ratio 300 - 4 phases

Series
829240

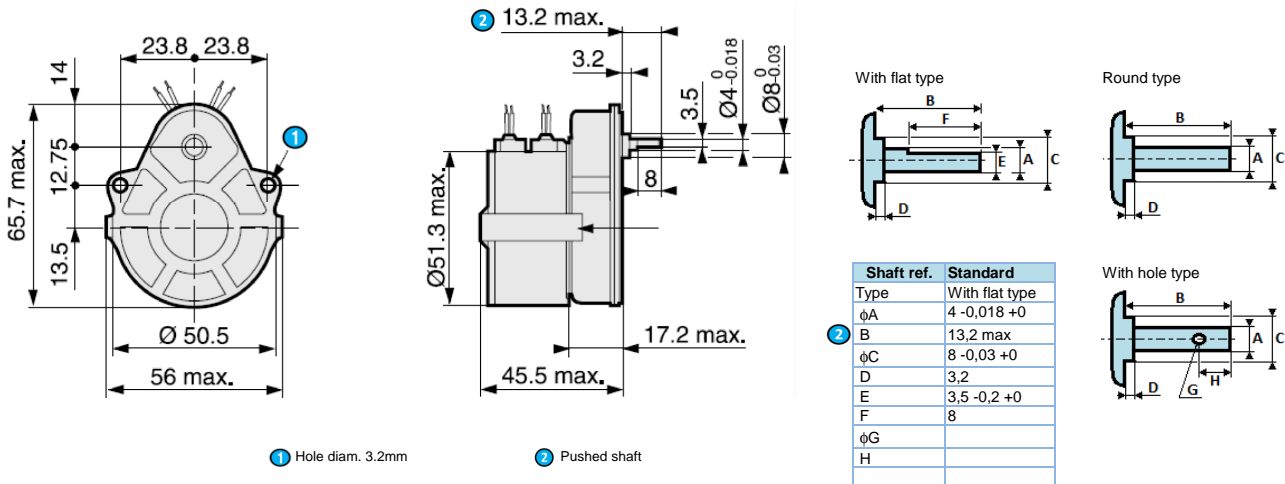

Product

Code	82 924 059		
Family	82924		
Type	Stepper gearmotor		
Definition	Motor 82920 1,7W 500 rpm nominal 7,5 °/t 48 step/t + Gearbox Ovoide ratio 300	4 phases 46 Ohms/phase	

General characteristics

Motor characteristics (1)		829200	
Motor type		829200	
Number of phases		4	
Input power	W	7,5	
Phase resistor	Ohm	46	
Phase inductance	mH	24	
Phase current	A	0,28	
Maintain torque	mNm	70	
Voltage per phase	Vcc	12,9	
Step angle	deg	7,5	
Step precision	%	5	
Rotor inertia	g.cm ²	18,8	
Max. detent torque	mNm	6	
Weight	g	210	
Output leads			
UL style 1569 105°C 300V - 6 leads AWG24		250 mm +- 10	

Gearmotor characteristics (1) (2)		A	B	C	D
Additional resistor /phase	Ohm	0	46	92	138
Voltage (phase + add. resistor)	Vcc	12,9	25,8	38,7	51,6
Max. output power	W	0,53	0,94	1,11	1,24
Speed at max. output power	rpm	0,9	1,4	1,6	1,6
Torque at max. output power	Nm	5,35	6,65	6,77	7,56
Max. current	A	0,28			
Weight	g	140			
Noise level	dBA	35			
Motor fixing on gearbox		<input checked="" type="checkbox"/> Clip		Screws	
Miscellaneous					
Dielectric (1s/2mA/50Hz)	CEI60335	Vac	600		
Motor insulation	CEI60085	class	B		
Degree of protection	CEI60529	IP	40		
Temperature range	CEI60068-2-1/2	°C	-30 -> +70		
Storage temperature		°C	-40 -> +80		
Approvals					
ROHS	2011/65/UE		<input checked="" type="checkbox"/>		
EC	2014/30/UE		<input checked="" type="checkbox"/>		

Notes	
Values without tolerance, are average production values.	
(1) Cold motor, 20 ° C ambient temperature, full speed	
(2) Without taking in count the torque gearbox limits, check gearbox characteristics	
(3) Continuously rated torque, zero radial and axial loads	
(4) Max torque for continuous operation at 20 ° C, decrease this value for higher ambient temperature	

Command sequence

Drive sequence for Clock Wise rotation

Step	1	2	3	4
1	-	-	-	-
2	-	-	-	-
3	-	-	-	-
4	-	-	-	-
5	-	-	-	-

Gearbox Characteristics		
Type	Ovoide	81021
ratio	300	
Shaft	standard	
Front bearing	brass	
Continuous max. torque	Nm	0,5
Max. Radial force (6mm from front face)	N	80
Max. axial force	N	10
Weight	g	275

